

*Hybrid-Composite Beam (HCB®)
Design and Maintenance Manual*



Bridge No. B0439 – MO 76 over Beaver Creek
Jackson Mill, MO

Prepared for
The Missouri Department of Transportation

John R. Hillman, PE, SE
HCB, Inc.

Final Draft - August 27, 2012

EXECUTIVE SUMMARY

The "Hybrid-Composite Beam" or HCB[®], is a structural member developed for use in bridges and other structures. The HCB is comprised of three main sub-components that are a shell, compression reinforcement and tension reinforcement. The shell comprises a fiber reinforced polymer (FRP) box beam. The compression reinforcement consists of concrete pumped into a profiled conduit (generally an arch) within the beam shell. The tension reinforcement consists of carbon, glass or more typically, steel fibers anchored at the ends of the compression reinforcement. The HCB combines the strength and stiffness of conventional concrete and steel with the lightweight and corrosion resistant characteristics of advanced composite materials. What results is a cost effective alternative for major infrastructure projects using state-of-the-art sustainable structures.

The intent of this manual is to provide the owners of HCB structures with sufficient information regarding the design, fabrication, construction and maintenance of the HCB so that they can maintain safe operability of the HCB Bridge over the duration of its service life. To this extent, the manual has been broken down into several sections to provide a concise overview that provides an understanding of how the bridge functions and where it differs from conventional concrete and steel bridges.

The HCB was originally conceived in 1996 and has been under development for many years, however commercialization of the technology in the form of serviceable structures was not initiated until 2008 with the construction of the High Road Bridge over Long Run Creek in Lockport Township, Illinois. The information provided in this manual is an attempt to represent the most current state-of-the-art of HCB Bridge technology, keeping in mind this technology will continue to evolve over time. The owner is encouraged to inquire about continued advances, not only in the development of the technology, but also with respect to inspection of HCB Bridges and structural health monitoring (SHM) of bridges in a more general sense.

As far as the organization of this manual, the first section is devoted simply to an overview of the technology in order to provide the owner with a general understanding of the inception, development and overall embodiment of the HCB. The second chapter serves as a design manual that provides more specific information with respect to the design limit states that are used to quantify the behavior of the HCB for specific applications and loads. This chapter will also continue to evolve with time and the intent is that continued analytical and experimental research will eventually lead to "Design Guide Specifications" that can be adapted by governing bodies such as AASHTO and AREMA. In the meantime, the information contained herein should provide sufficient information to replicate the design calculations and quantify the structural capacity and performance of an HCB bridge.

The third chapter in the manual begins to identify some unique aspects of the materials and material behavior with respect to serviceability and extreme events that could occur during the life of an HCB structure. This section also delves into possible measures that can be used to mitigate or minimize damage to the structure from certain environmental degradation or extreme events. This section is not intended to be all-inclusive and it is anticipated that it will continue to evolve over time to include additional measures as advances in material science warrant.

The fourth chapter is meant to be more project specific with the intent of addressing design, fabrication and construction processes for a specific structure. Examples might include whether or not the compression reinforcement was cast prior to erection of the HCB's or whether it was placed after erection of the HCB's. It will also attempt to identify project specific items such as types of bearings, expansion joints, drainage systems or other attached appurtenances as well as assumed fixity and boundary conditions for analysis. This is a non-exhaustive list and where possible, the manual will try to include project specific photographs showing the as-built condition of the completed structure.

One of the more important elements of this design manual is providing the owner with valuable information as to what could go wrong with an HCB Bridge, and if something does go wrong, where to look for guidance in remediating the problem. Chapter 5 is intended to provide guidance in terms of inspection and maintenance procedures addressing the current state-of-the-art for structural health monitoring and subsequent repair techniques for fiber reinforced polymer (FRP) and/or HCB structures.

To provide a full record of the HCB structure, this manual also includes numerous Appendices related to design, fabrication, construction, quality control and quality assurance and any project specific laboratory or field-testing related to the performance of the structure. This includes calculations, construction documents and shop drawings.

TABLE OF CONTENTS

EXECUTIVE SUMMARY 1

1.0 INTRODUCTION AND GENERAL PRINCIPALS 1

 1.1 THE HYBRID-COMPOSITE BEAM (HCB®) 1

 1.2 HISTORY OF DEVELOPMENT 3

 1.3 FEATURES AND BENEFITS 4

2.0 STRUCTURAL DESIGN AND ANALYSIS 6

 2.1 LIMIT STATES METHODOLOGY 11

 2.2 DEFLECTIONS 11

 2.3 POSITIVE MOMENT BENDING 13

 2.4 NEGATIVE MOMENT BENDING 19

 2.5 VERTICAL SHEAR 20

 2.6 HORIZONTAL SHEAR 21

 2.7 FATIGUE CONSIDERATIONS 23

 2.8 LOAD RATING METHODOLOGY 23

3.0 MATERIAL & STRUCTURAL DAMAGE SERVICEABILITY CONSIDERATIONS 24

 3.1 ULTRAVIOLET RADIATION 24

 3.2 FIRE RESISTENCE 24

 3.3 THERMAL EXPANSION 25

 3.4 LATERAL IMPACT 25

4.0 CONSTRUCTION DETAILS (PROJECT SPECIFIC) 27

 4.1 FABRICATION DETAILS 27

 4.2 ADHESIVE BONDS 28

 4.3 BEARING DETAILS 28

 4.4 PARAPET DETAILS 28

 4.5 DRAINAGE DETAILS 28

 4.6 SEQUENCE OF INSTALLATION 29

 4.6.1 Casting of Arch-Compression Reinforcement 29

 4.6.2 Shipping and Erection 30

 4.6.3 Casting of Composite Concrete Deck and Parapets 31

5.0 INSPECTION AND MAINTENANCE 32

 5.1 INSPECTION METHODS 32

 5.2 DETERMINATION OF RATING FOR HCB 34

 5.3 STRUCTURAL HEALTH MONITORING 35

 5.4 REPAIRS 36

 5.5 DECK REPLACEMENT 36

REFERENCES 37

APPENDIX A – Design Calculations 38

APPENDIX B – Load Rating Calculations 38

APPENDIX C – Design Drawings & Specifications 38

APPENDIX D – Shop Drawings 38

APPENDIX E – QA/QC Documentation 38

APPENDIX F – Project Information Sheet - Material Certification Reports 38

APPENDIX G – Laboratory Test Report (Optional) 38

APPENDIX H – Field Test Report (Optional) 38

1.0 INTRODUCTION AND GENERAL PRINCIPALS

1.1 THE HYBRID-COMPOSITE BEAM (HCB[®])

Considerable work has been done since the late 1980's to the present day with respect to Fiber Reinforced Polymer or FRP elements for transportation infrastructure applications. In order to emphasize the unique characteristics of the HCB, it is important to point out that most of the research in advanced composite materials for transportation applications has been limited to structural shapes comprised of homogeneous FRP materials. Other research includes the application of FRP materials to conventional structural members to enhance strength and serviceability. The following is a non-exhaustive list of the various FRP research categories with respect to the bridge industry:

- Bridge framing systems using glass FRP beams or trusses manufactured from pultruded shapes.
- Glass FRP cable stayed pedestrian bridges fabricated from pultruded shapes with FRP cable stays.
- FRP reinforcing bars and post-tensioning strand for reinforcing and prestressing conventional concrete beams.
- Bonding FRP sheets to existing concrete and steel structures as a means of repairing, strengthening and upgrading these structures.
- FRP column wraps to provide confinement for enhanced seismic performance of concrete columns.
- Concrete filled, circular FRP tubes as an alternate to reinforced concrete columns.
- FRP bridge decks manufactured as pultruded sections, or VARTM sandwich panels.
- Hybrid pultruded beams using carbon reinforced flanges and glass-reinforced webs.

In most cases, where bridges have been constructed of structural members fabricated entirely of FRP, these bridges are subject to constraints that have precluded widespread acceptance of the technology. First and foremost has been cost. The increased costs can be directly traced to raw material costs and inefficiencies due to constitutive material properties. In general, both glass and carbon have a strength capacity that meets or greatly exceeds that of steel. However, these materials are much more flexible and typically require additional material beyond what is required for strength to satisfy the serviceability requirements for deflections. The amount of material required for deflection control coupled with the higher material costs have traditionally made it more difficult for a purely FRP beam to be cost competitive with concrete or steel beams.

Other limitations in application and span length constraints for FRP beams have resulted from lower shear strength capacity and low elastic buckling capacity in compression. Combined with the flexible nature of these materials, applications of purely FRP bridges have generally been confined to pedestrian bridges and short span county bridges. Although the increased service life can improve the life cycle costs, FRP structures built in the early years of development were seldom, if ever, cost effective on a first cost basis.

What distinguishes the HCB from some of the earlier FRP structures is that it uses conventional materials, i.e. concrete and steel, in conjunction with FRP components to create a structural member that exploits the inherent benefits of each material in such a manner as to optimize the overall performance of the combination of materials. Whereas FRP materials are generally too expensive and too flexible when arranged in a homogeneous form, the strength and stiffness in the HCB are provided by a more efficient use of materials that are well suited to purely axial tension or compression. The classical arch shape of the compression reinforcing also helps reduce the shear carried by the FRP webs and ensures an optimal use of the compression and tension reinforcing. The culmination is a composite beam system that provides lighter weight for transportation and erection with enhanced corrosion resistance that can be cost competitive with conventional materials on a first cost basis.

In its most general form, the HCB is comprised of three main sub-components that are the shell, compression reinforcement and tension reinforcement. The first of these is the FRP beam shell, which encapsulates the other two sub-components. The second major sub-component is the compression reinforcement which consists of portland cement grout or concrete which is pumped or pressure injected into a continuous conduit fabricated into the beam shell. The third and final major sub-component of the beam is the tension reinforcement, which is used to equilibrate the internal forces in the compression reinforcing. This tension reinforcing could consist of unidirectional carbon or glass fibers or it could consist of steel fibers, e.g., standard mild reinforcing steel or prestressing strand infused in the same matrix during fabrication of the glass beam shell. The orientations of these sub-components are graphically displayed in Figure 1.1. As a result of the orientation of the materials, the concrete, for the most part is in pure compression. The steel is in pure tension. As noted previously the arch profile of the compression reinforcement allows for much of the shear to be carried by the concrete.

Subsequently, the FRP webs of the beam can be made relatively thin, resulting in a more efficient use of the FRP in the shell.

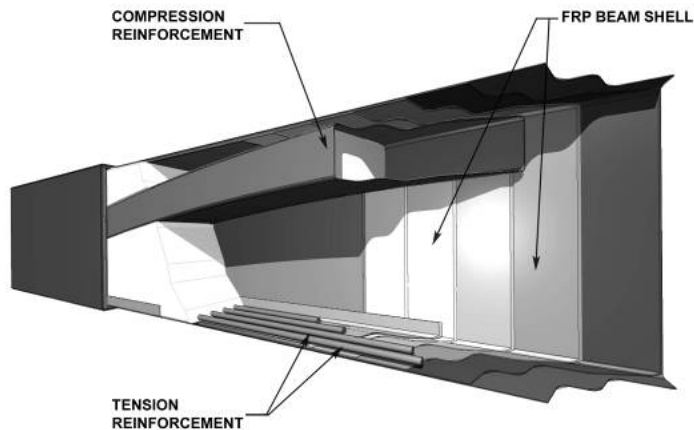

FIGURE 1.1 - Fragmentary Perspective of Hybrid-Composite Beam

Despite the unique configuration and diverse nature of the building materials used in the HCB, the end product does not result in any unique characteristics that preclude the beam from being used in the same manner as more conventional framing systems. The cross-section is very conducive to standardization, similar to prestressed beams or rolled steel sections. Yet at the same time the tooling required for the Vacuum Assisted Resin Transfer Molding (VARTM) manufacturing process is simplistic and inexpensive and allows for considerable variation with respect to overall dimensions, shape and internal lay-up. The embodiment of the HCB results in a beam that has several inherently unique benefits, while remaining cost competitive with conventional materials.

The beam shell is constructed of a vinyl ester resin reinforced by glass fibers optimally oriented to resist the anticipated forces in the beam. The beam shell includes a top flange, bottom flange and a continuous conduit. The conduit is fabricated into the shell and runs longitudinally and continuously between the ends of the beam along an arch profile that is designed to conform to the internal load path resisting the external forces applied to the beam. The beam shell also includes two vertical webs, which serve to transfer the applied loads to the composite beam as well as to transfer the shear forces between the compression reinforcement and tension reinforcement. All of the components of the beam shell are fabricated monolithically using the VARTM process.

The compression reinforcement, which typically consists of self-consolidating concrete (SCC), is pumped into the conduit within the beam shell through the ports located at the centerline and ends of the beams (depending on the lengths of the beams, there may be additional ports at 15 to 20 foot spacing). The profile of the compression reinforcement follows a parabolic profile which starts at the bottom corners of the beam ends and reaches an apex at the center of the beam such that the conduit is tangent to the top flange. The profile of the compression reinforcement is designed to resist the compression and shear forces resulting from vertical loads applied to the beam in much the same manner as an arch structure.

The thrust resisted by the compression reinforcement resulting from externally applied loads is equilibrated by the tension reinforcement. The tension reinforcement consists of layers of unidirectional steel reinforcing fibers with a high tensile strength and high elastic modulus. The fibers, which are located just above the glass reinforcing of the bottom flange, are oriented along the longitudinal axis of the hybrid-composite beam. The tension reinforcement is fabricated monolithically into the composite beam at the same time the beam shell is constructed. Subsequently, the strands are completely encapsulated in the same resin matrix as the glass fabrics. The most common type of tension reinforcing used today in HCB's is 270 ksi, galvanized, prestressing strand.

A bridge can be built quickly and easily using the HCB. The beams are typically erected prior to injection of the compression reinforcement by placing them with a crane in the same manner as a steel or prestressed concrete beam. The composite beams are easily self-supporting prior to and during the installation of the compression reinforcement. In the case of bridge replacement or rehabilitation it may be possible to reuse existing abutments and/or intermediate piers. The compression reinforcement is then introduced into the composite beam by placing the portland cement concrete into the profiled conduit in the FRP beam shell. No temporary falsework is required for the erection of the composite beams or during the installation of

the compression reinforcing. For some applications, such as railroad bridges, it may be desirable to cast the compression reinforcing prior to shipping the beams to the project site. This was the case in the prototype bridge first installed on the railroad test track. Although a railroad bridge constructed using HCB can still be less than half the weight of a concrete bridge, speed of installation for railroad bridge construction is generally more important than extreme lightweight.

There are also cases where the arch concrete will be placed prior to erection of the HCB's, but the concrete deck is still cast-in-place. Any time portions of the concrete are precast prior to erection, the pick points for the beam become more sensitive. With the empty shell, the beams can be picked from almost any location. Once the concrete arches are cast, it is important to lift the beams from the ends to avoid introducing tension stresses in the arch concrete. In most cases, strand lifting loops or other lifting inserts are placed in the chimneys at the ends of the beam prior to arch casting, to provide the requisite lifting devices.

For most typical applications, the weight of the HCB during transportation and erection is approximately one fifth of the weight of the conventional steel beam required for the same span and approximately one tenth of the weight required for a precast prestressed concrete beam for the same span. This light weight coupled with the corrosion resistant nature of the FRP materials make this technology well suited to "Accelerated Bridge Construction" and for providing bridges with service lives that should exceed one hundred years.

1.2 HISTORY OF DEVELOPMENT

John Hillman originally conceived of the HCB in 1996. The early development of the design limit states, fabrication processes and structural validation began with a series of Innovations Deserving Exploratory Analysis (IDEA) grants from the Transportation Research Board (TRB) beginning in 1999. The initial study for the High Speed Rail IDEA program began with HSR-23; "Investigation of a Hybrid-Composite Beam System". This investigation resulted in initial quantification of cost metrics, development of limit states equations for analysis and proof of concept through load testing of the first 20-foot prototype Hybrid-Composite Beam fabricated at the University of Delaware¹. This first beam was constructed using 1-3/8" diameter post-tensioning bars for the reinforcing steel and the arch was constructed of high-strength non-shrink grout installed in the arch cavity prior to infusion. Although the beam was not very attractive, it did stand up to the design loads and on February 1, 2002, the first HCB was loaded to failure at an ultimate load that was 180% of the factored design loads, or almost twice as strong as required by code.

High-Speed Rail and the National Cooperative Highway Research Program (NCHRP) jointly funded the second IDEA grant beginning in 2003. The objective of Project HSR-43 investigation was to perform a product demonstration that included fabrication; erection and monitoring of a full size 30-foot prototype railroad bridge constructed using HCB technology. Similar to the initial IDEA project, the development, fabrication and testing of the 30-foot HCB units for HSR-43 was conducted at the University of Delaware in conjunction with the Civil Engineering Department and the Center for Composite Materials (CCM).

The final location of the in-situ testing of the complete HCB bridge was not concluded until late summer of 2007. The final decision to test the bridge on the Heavy Axle Load (HAL) FAST loop at the Transportation Technology Center, Inc. (TTCI) in Pueblo, Colorado was finally cemented when a consortium of Class 1 Railroads stepped up to provide the funds for the installation and train operations for the testing during the summer of 2007. This consortium included BNSF, Canadian National, Canadian Pacific, Norfolk Southern and Union Pacific. With the funding finally in place, the final objective of this investigation could be realized and the first HCB Bridge was actually constructed and tested under full Class 1 Railroad service loads. The results of the four stages of the HSR-43 investigation are as follows:

Stage 1: Stage 1 was dedicated to the fabrication of one 30-foot prototype girder representative of the beams to be used in the final product demonstration. Before getting to the fabrication of the 30-foot prototype, extensive manufacturing experiments were conducted on smaller scale beams of 8-foot length to determine tooling, lay-up and infusion techniques that could be scaled up for fabrication of larger beams. Fabrication and testing of the first 30-foot beam was conducted. Due to a glitch in saving the load test data from the first test, a second 30-foot beam was also fabricated and tested in the laboratory in September of 2005. Both successful laboratory tests yielded similar results and demonstrated that the prototype beams met all performance requirements in accordance with AREMA recommended practices.

Stage 2: Following completion of Stage 1, the next stage of the investigation was dedicated to the fabrication of eight (8) 30-foot beams to be used in the prototype bridge installation as part of Stage 4. The Stage 2 efforts proved more

difficult than anticipated, as the manufacturing techniques continued to evolve over the course of the project until an infusion process was arrived at that was simplistic and consistent in terms of the quality of the beams. In addition to the fabrication studies, standards for design, and shop and erection drawings related to the construction of HCB bridges were developed and documented.

Stage 3: Stage 3 was interjected into the project to address other technical aspects of this composite technology as they relate to questions that have come up from representatives of the bridge industry. This stage of the investigation addressed many of the aspects related to the preparation of the beams for deployment in the prototype installation as well as issues related to maintenance, durability, fire resistance and other constructability and performance related issues. Guidelines for material specifications as well as references for documents related to long-term monitoring of FRP transportation structures were also developed.

Stage 4: The last and final stage of the HSR-43 investigation culminated with field-testing of the first HCB Bridge at the Transportation Technology Center, Inc. (TTCI) on November 7, 2007.

1.3 FEATURES AND BENEFITS

The HCB provides an alternative for consideration in replacement of our deteriorating bridges. Some of the inherent benefits of the beam are as follows:

- **Straightforward Production:** The HCB is fabricated in a controlled shop setting without any special equipment, expensive molds or handling equipment. Glass fiber reinforcement and steel tension reinforcement placement is done quickly and efficiently, increasing product quality and reliability while reducing fabrication labor costs.
- **Reduced Shipping Costs:** An empty HCB weighs only 10% of a comparable concrete beam making it possible to ship up to six beams on one truck as compared to one beam per truck for precast concrete.
- **Ease of Installation:** The HCB can be quickly installed at the site with only light duty cranes or excavators. HCBs do not require complicated bracing and diaphragms as compared to typical steel framed structures. The simplicity of installation provides advantages to small, local contractors as much as it does to large heavy civil construction firms.
- **Sustainable:** With a composite exterior, the HCB product has a high degree of protection and is inherently corrosion-resistant, offering service lives beyond 100 years with little or no maintenance. The HCB also uses 60% to 80% less cement than a comparable concrete beam. Cement production accounts for 3.4% of CO₂ emissions worldwide, making it one of the largest contributors to the carbon footprint globally.
- **Increased Safety:** Since HCB design is controlled by deflection limits, strength capacity typically exceeds code requirements by at least 10% to 60%. The significantly lower mass and high strength energy absorbing FRP shell provide for a highly resilient structure under seismic loads.
- **Low Initial Cost:** The HCB utilizes higher-cost composite materials only for the shell of the beam. The primary strength and stiffness comes from much lower-cost concrete and steel. This combination results in a cost effective system that is superior to conventional materials and can compete economically on an installed, first cost basis.
- **Adaptable:** The low weight of the HCB makes it a perfect component for prefabricated modular construction. The rapid replacement of bridges is becoming more important with increasing traffic volumes. Railroads also count on prefabricated modular units to minimize outages on revenue service lines. In the case of railroad installations, a completed HCB bridge superstructure is one half the weight of a conventional precast concrete structure. Prefabricated Railroad Bridge Modules, including the concrete deck, ballast curbs and fall protection and can completely replace an existing bridge in a matter of hours, not days.

Regarding safety in structural capacity, the design of the HCB is generally governed by live load deflections limitations. This serviceability criterion is met by adding additional tension reinforcement, which is typically a very high-strength (270 ksi) prestressing strand. This additional steel added for deflection control provides additional strength capacity to the beams. It is not unusual to see laboratory tests, where the ultimate capacities of the beams yield Inventory Load Ratings of 2.68 (HS-54) and Operating Load Ratings as high as 3.47 (HS-69). These ratings are based on the AASHTO

Load and Resistance Factor Rating Guide Specifications and demonstrate that the load carrying capacities of the HCB are well in excess of what is required by the factored demand in the design codes.

Regarding the HCB's sustainability, FRP's are lightweight and strong. This greatly reduces the mass of the superstructure, reducing the size and complexity of the substructure. FRP's also have proven to be corrosion resistant which can ideally extend the service life to more than 100 years. In addition, the low fatigue levels at service load also ensure a longer life. Lastly, FRP composites do not become brittle in cold temperatures meaning they are ideal for cold climates.

These are but a few characteristics that substantiate the benefits of using HCB technology in place of conventional steel and concrete structures.

2.0 STRUCTURAL DESIGN AND ANALYSIS

In order to assess the limit states that are required to quantify the behavior of the hybrid-composite beam system, it is worth briefly considering the general evolution of structures through the course of time. Some of the first structures ever contrived were stone arches. Without any calculations at all, it became evident that by placing blocks of stone sequentially in a circular curve, it was possible to create a structure that would span a distance equal to the diameter of the circle. Centuries later, with the advent of materials such as iron and steel, it became possible to span greater distances with much lighter structures. As the steel rolling mills and fabrication technology became more sophisticated, complex riveted trusses gave way to sleek rolled sections and welded plate girders.

Engineers continued to experiment with hybrid structures, utilizing more than one type of building material to comprise a structural member. One of the most simplistic concepts in the history of structural engineering, which is now completely taken for granted, is the concept of adding reinforcing steel to a concrete beam to dramatically increase the load carrying capacity of the member. Nowadays, we simply refer to these as concrete beams. However in actuality they are really hybrid-composite structures, relying on a more optimized utilization of two very different materials.

In almost every instance, as engineers create new structural forms, it is necessary to develop a methodology for quantifying the behavior of the various materials within the specific embodiment intended. Such is the case with the evolution of fiber-reinforced polymers (FRP). In general, various methods of structural analysis that evolved for other types of materials can also be applied to the analysis and design of FRP structures. Certainly statics is applicable. The theory of elasticity and general mechanics of materials also remain essentially unchanged, particularly as they apply to conventional materials such as steel.

There are two fundamental assumptions that differentiate FRP structures from steel structures. One difference is that steel is assumed to be elastic, perfectly plastic. In other words, the stress strain relationship for this material can be accurately represented with a bifurcated, bilinear curve. This property also allows the steel to undergo a significant increase in strain after reaching its yield strength and prior to a brittle rupture. The other property of steel that grossly simplifies analysis and design is that it is an isotropic material. In other words, it has essentially the same constitutive properties in all directions.

In contrast to steel, FRP materials generally remain linearly elastic up to the point of a brittle failure mode. To further complicate analysis, FRP structural components are anisotropic rather than isotropic. In other words, the constitutive properties of these materials can vary in each direction, and are a function of the specific composition of the material. In the case of glass fiber reinforced composites and carbon fiber reinforced composites, the strength and stiffness properties are typically a function of the fiber volume ratios and the specific orientation of the fibers. Because of these fundamental differences, FRP structures require additional consideration in design and analysis. An in depth derivation of the theory of elasticity for non-linear, non-isotropic material behavior is beyond the scope of this project. However, this information is available in numerous texts and will be elaborated on where it is necessary to evaluate certain limit states. One generalization that can be made is that, based on the development to date, it is not evident that a rigorous analysis of the FRP materials is warranted to arrive at a safe and functional design.

Computational Development: By definition, the HCB is comprised of several different materials. Each component of the beam serves at least one specific structural purpose. The concept behind the HCB is to select materials that are well suited to satisfying particular design limit states, and arranging them in such a manner as to optimize the structural behavior of the overall beam. In general terms the HCB is comprised of three main sub-components that are the shell, the compression reinforcement and the tension reinforcement. With regard to some limit states, the HCB behaves similar to a reinforced concrete beam. In some respects, it behaves similar to a steel box beam. Finally, with respect to many of the limit states, the FRP components do contribute to the resistance. As a result, some additional consideration has to be given to the analysis of these components of the structure.

One of the primary goals in developing an efficient design for any structure is to determine a predictable mode of failure and attempt to provide an optimized design for all of the limit states such that the intended failure mode will still govern. It was not evident in the early stages of HCB development, how each limit state would be quantified, or how the behavior of each different component of the beam would influence the design. Because of this lack of intuitive knowledge, the development of a design spreadsheet was initiated that would provide a means of investigating the limit states simultaneously to facilitate quick preliminary designs. Subsequently, these design tools make it possible to

investigate the impacts to all limit states, as modifications are made to a specific component and perform parametric studies to converge on more efficient designs.

The following sections of this report will provide a more detailed discussion of the more critical design limit states considered in the development of the HCB. This information can serve as a guide in performing and/or reviewing design calculations for a specific bridge. The following list identifies how the design is compartmentalized to facilitate book keeping during design:

- INPUT
- SECTION
- DESIGN LOADS
- SHEAR
- DEFLECTIONS
- BENDING (NON-COMPOSITE)
- BENDING (COMPOSITE)
- BENDING (NEGATIVE MOMENTS)
- STRESSES (POSITIVE BENDING)
- STRESSES (NEGATIVE BENDING)

The initial design spreadsheet compiled includes a live load generator for calculation of simple span moments for:

- HS-20 (Lane and Truck Loads for AASHTO Standard Specifications)
- HL-93 (Lane and Truck Loads for AASHTO LRFD Specification)
- Cooper E-80 (Locomotive and Alternate Load for AREMA Specifications)
- Uniform Live Load (For building applications or alternate pedestrian loads on bridges)

Where bridges are designed to be continuous for live loads, a separate live load generator is suggested. The current design spreadsheet tools have been set-up for post-processing once the design live load forces have been calculated at 1/10th points along the beams. Other types of live loads can be evaluated as well, but the designers are cautioned to pay special attention to the bookkeeping, as the HCB does not have prismatic section properties.

INPUT: The INPUT section of the design calculations is primarily to establish the bridge geometrics, the constitutive properties for the various materials, the governing code for evaluation and any corresponding unit weights or loads that need to be evaluated based on the structure type. Regarding unit weights and loads, this applies primarily to dead load and superimposed dead loads such as parapets, future wearing surfaces, ballast, rails, etc. For the most part, this input information is specific to a bridge project and not unique to the HCB, with the exception of some of the constitutive properties of the FRP materials.

SECTION: In order to perform the serviceability and strength capacity checks for the HCB, it is necessary to define the exact section under consideration. The information specific to the geometry of the HCB is input in SECTION. This information is used to define the cross-section of the HCB and calculate the section properties. Demonstrated in Figure 2.1 is a generalized beam cross-section showing both steel tension reinforcing and supplemental fiber tension reinforcing, which could be carbon or additional glass fabric.

Due to the isotropic nature of steel, it is possible with steel structural members to calculate the area and inertia of the cross-section without consideration of the elastic modulus. In calculating the section properties of the HCB, it is necessary to consider the relative constitutive properties of the various materials used. As a result it is necessary to select the elastic modulus of one material to serve as the basic value to be used in analysis. In the case of the HCB, it was determined that a logical choice for the base material would be the glass FRP webs. The primary reason being that this is the material most likely to remain relatively constant whereas the material selected for the compression and tension reinforcing could result in dramatically different elastic moduli. Further, the elastic modulus of concrete is not well suited as a constant, in that as concrete approaches its ultimate strain, the material cannot be accurately represented with a constant value for the elastic modulus.

By selecting one material as the reference, all of the other materials comprising the beam are then transformed into equivalent areas of this same material using the respective modular ratios “n”. As a result, the modular ratio used for transforming steel tension reinforcing to an equivalent amount of FRP would be $n_s = E_{\text{steel}}/E_{\text{web}}$ and likewise for the other

materials. The modulus of elasticity assumed for the laminate is typically based on the constitutive properties acquired from ASTM tests on witness panels made during the fabrication of previous beams. The properties can also be calculated using equations based on the rules of mixture of the glass and resin components as is common in the composite industry. However the test data yields more accurate results and has historically provided excellent accuracy in calculating the predicted deflections. It should be noted that for all intents and purposes, the foam component is ignored in the calculations. Although the foam is neglected in calculations, it does serve several important purposes that will be discussed in more detail later.

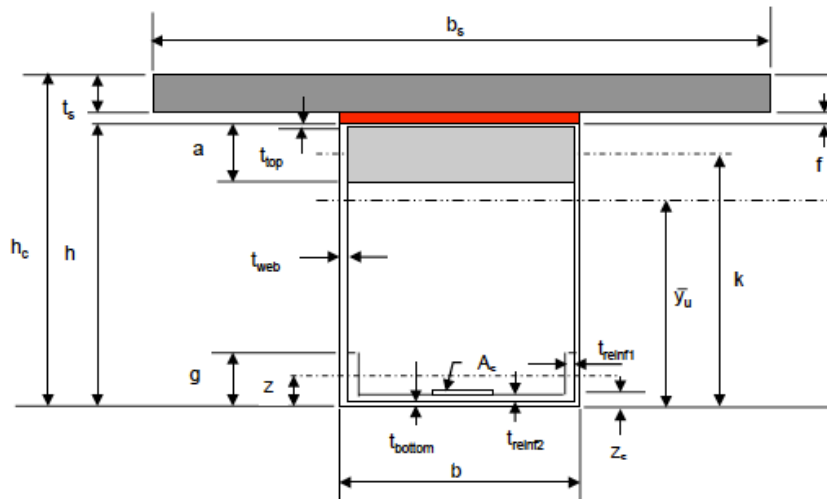

Figure 2.1 - Typical Cross-Section Geometry

In calculating the cross sectional properties for the HCB, it is important to remember that due to the profile of the compression reinforcement, the section properties are not prismatic along the length of a beam. As a result, the section properties are calculated at 1/10th points along the beam based on a parabolic profile of the compression arch. Due to the construction sequencing of the HCB, it is also necessary to calculate separate properties for the HCB shell by itself; the HCB shell acting compositely with the concrete arch and the full composite properties of the HCB with the arch concrete and the composite concrete deck.

Once all of the geometric data and constitutive properties of the materials have been input, the cross-sectional areas and moments of inertia can be tabulated for the beam under consideration. It is also at this time that the self-weight of the structural member is calculated, both with and without the compression reinforcing in place. The calculated properties of the section are then used in subsequent calculations to help design the components of the beam for the various design limit states.

DESIGN LOADS: The design loads for consideration on the bridge are typically governed by specific codes. In the USA these codes generally include the American Railway Engineering and Maintenance-of-Way Association (AREMA), Manual for Railway Engineering, and for highways, the American Association of State Highway Transportation Officials (AASHTO) LRFD Bridge Design Specifications. Ultimately the owner usually dictates the governing loads for design of a bridge. The following is a brief description of the book keeping procedures necessary to compile the design forces and allow the designer to tailor the calculations to a specific application.

Bridge Geometrics and Composition: In this section, the designer must define the cross section of the overall structure to be considered. In most bridge designs, it is acceptable to distribute superimposed dead loads uniformly to all of the beams in a cross section. As a result, in defining the cross-section, the designer must identify all of the superimposed dead loads to be applied to the cross-section. Some of the information in this section might include:

- Span Length
- Deck Width
- Depth of Ballast

- Slab Thickness
- Parapet Loads
- Overlay Thickness and Weight
- Rail Loads

Dead Loads: Once the number of girders to be included in the overall cross-section of the structure as well as the girder spacing has been selected the dead loads per unit length of beam can be calculated.

Superimposed Dead Loads: In many cases, portions of the dead loads on a structure may be placed or removed at a later time within the life of the structure. As a result, most design codes require that these loads be tracked separately than the basic dead loads. Superimposed dead loads typically include items such as parapets, overlays, future wearing surfaces, ballast, or in the case of buildings it could include items such as interior partitions.

Live Loads: The design live loads can vary dramatically depending on the specific application of the structure. For Class 1 Railroad bridges, live loads typically consist of the Cooper E-80 Load or the Alternative Live Load as specified in AREMA. For highway bridges, the design load considered is the HL-93 load as specified by AASHTO. For building loads, the designer must input a uniformly distributed pressure. The information provided previously, including the number of girders and the beam spacing are used to calculate the distribution of live loads to the specific beam under consideration. The span length previously entered is used to determine the impact factors to be applied to live loads for highway and railroad bridges.

As noted before, the tool developed for preliminary designs does include a live load generator that is sufficient for simply supported single spans under conventional AASTHO and AREMA loads. When girders are to be designed as continuous structures, the design forces should be calculated from a more rigorous analysis and input into the design program manually. It is expected that in the near future, commercial grade software will be available that includes a more generic live load generator that works for continuous structures as well as simple spans.

Maximum Design Forces: Once all of the dead, superimposed dead and live load forces have been determined for a specific beam, these forces are compiled and combined to calculate the controlling forces for the limit states of shear and bending. The unfactored loads are considered service loads. The factored loads are also calculated using the designated load factors to be considered in ultimate strength design for various load combinations as specified in the governing design codes for the respective bridges. Primary differences between applications such as railroad bridges and highway bridges are in externally applied loads, beam spacing relative to structural cross-section, safety factors and load and resistance factors.

There are various different classifications of limit states that are applicable to structural analysis and design. HCB design considers both strength and serviceability limit states. Strength limit states are typically those that must be satisfied in order to ensure the safe performance of a structure. Serviceability limit states are those that are generally evaluated based on subjective criteria relative to an acceptable level of performance, as determined by the user, relative to a specific behavior of the structure, e.g. deflections or vibrations. It should be noted that with greater optimization of strength limit states for a structure, the controlling design criteria of serviceability limit states could become less prevalent. This is often typical of lightweight structures and has also been evident through the development of FRP structures utilized in civil applications.

Before progressing into the specifics of the various limit states, it is worth briefly mentioning the differences between the two design philosophies that are typically used with respect to structures of all types. One philosophy is typically known as working stress design (WSD) or allowable stress design (ASD). In this system, the loads applied to a structure are intended to represent forces with magnitudes that represent a realistic occurrence. The stresses in the structural members are then calculated from these realistic loads and compared to an allowable stress based on a failure stress, such as yielding of the material, divided by some factor of safety.

The second design philosophy is sometimes referred to as ultimate strength design (USD). Another terminology used is load and resistance factor design (LRFD). In this system, the design codes typically use the same service loads as in WSD, however, these loads are then amplified by load factors. The stresses, or more appropriately, the internal forces resisting the applied loads in the structural members are calculated to resist these factored loads. The ultimate capacity of

the section is calculated based on some limiting parameter such as yield strength, ultimate strength, limiting strain or elastic buckling strength of the material multiplied by some resistance factor that is generally less than 1. If the response of the structures is such that the ultimate capacity of the section is found to be greater than the factored demand on the section, then the specific design limit state under consideration is satisfied. Again, a comprehensive discussion of LRFD is beyond the scope of this manual and is available in great detail in other texts.

It is generally preferable to select one design philosophy or the other and remain consistent throughout the design and analysis of a structure. In some cases there is a duplicative evaluation of a design limit state using both philosophies. One instance of this is in the design of prestressed concrete beams where it is common to design according to some pre-determined allowable stresses for the materials (ASD), but still check the ultimate capacity of the beam using LRFD. For the HCB a reverse approach is taken, where the strength checks are performed using an LRFD approach, but the stresses under service conditions are also checked to make sure the structure is safe under each stage of construction and service. This will be addressed in more detail in subsequent sections of this manual.

Based on bridges designed and constructed to date, the structural behavior of the HCB consistently indicates that serviceability and more specifically, live load deflections govern the design. The following is a brief listing of the steps used in making decisions regarding the composition of the beam to arrive at a satisfactory design. More specific descriptions of each limit state will be discussed in more detail later.

- Establish geometrics of structural cross section.
- Make initial assumption regarding depth of girders. For railroad bridges this is typically span/10 to span/12. For highway bridges, the optimum range is span/18 to span/25.
- Make initial assumption of girder width based on depth (generally depth/3 to depth/2). Typical width of 24 inches is driven by efficient use of foam core that has standard widths of 24 inches. A single block of foam is desirable in the bottom of the beam and by using common off-the-shelf dimensions, then there is no waste of the material.
- Make preliminary assumption on thickness for FRP web and flange components. Common web thicknesses are two layers of Q64 fabric or one layer of Q102 fabric combined with a layer of X24 (these will be explained in more detail later). Either way a typical laminate thickness on the shell is on the order of 0.15 inches.
- Adjust dimensions of compression conduit and amount of tension reinforcing until deflection criteria are met. Typical dimensions of the compression arch might be 1/6 to 1/5 of the depth of the shell. The most effective ways to reduce deflections are increasing the depth of the beam and adding tension reinforcing to the bottom flange.
- Check the ultimate moment capacity of the shell and arch during placement of the deck concrete (neglecting composite action with the deck).
- Check the ultimate moment capacity of the HCB acting compositely with the deck to make sure strength is satisfied for full dead plus live loads. Adjust compression and tension reinforcing as required, although typically the use of high-strength prestressing strand results in residual capacity beyond the factored demand in the codes.
- For structures made continuous for live loads, it is also necessary to check the ultimate bending capacity over the piers. At centerline of the piers, this capacity is typically limited to the tension reinforcing in the deck and the compression block available in the HCB arch.
- Check ultimate shear capacity at 1/10th points along the beam. Increase web thickness if necessary.
- It is also important to check the positive moment stresses in each component of the beam due to bending under service level loads. In the case of continuity the negative moment bending stresses must also be checked.

This is by no means a comprehensive list of the steps necessary to design an HCB Bridge, but the steps shown are intended to serve as a guideline to performing a design. It is also intended to provide some historical background to explain where specific dimensions on an HCB may have come from when looking at future structural evaluations and load ratings.

2.1 LIMIT STATES METHODOLOGY

As is the case for the design of conventional concrete and steel structures, the design philosophy and limit states for the HCB will continue to evolve with further research. A logical argument can be made regarding the use of load and resistance factor (LRFD) design philosophy based on the prevalence of this philosophy in current structural design codes worldwide. At the same time, serviceability limit states, such as deflections, should be evaluated with unfactored loads, which is standard practice for most structures. Also like steel and concrete, the limit states for shear are much more complex and in some cases may require both ASD and LRFD checks for the HCB. It should be noted that when evaluating the performance of FRP materials, it is not unusual to use limiting strains rather than limiting stresses, as is typically done for steel and concrete structures. This will be discussed in more detail in the bending limit state check.

As noted previously, most structural design codes now use an LRFD format. As part of future development for code provisions, reliability analyses should be conducted for each limit state with respect to the statistical probability of the demand and capacity of the beam based on the materials used in the HCB to arrive at more specific load and resistance factors. For now, due to the similarities of the HCB to a reinforced concrete beam, it seems reasonable to use the load and resistance factors in the AASHTO and AREMA codes to safely design an HCB Bridge. The factored demand required by these codes for shear, bending, fatigue and deflection limit states have all been consistently substantiated through laboratory testing of prototype beams.

2.2 DEFLECTIONS

Deflection of a structure is a serviceability limit state that usually has to be satisfied, regardless of the intended use of the structure. It is important to address this limit state first, as FRP structures are very sensitive to meeting the deflection requirements of most structural codes. In fact, designing for deflection criteria has consistently been one of the major constraints to the wide spread use of FRP structures in civil applications, and was the primary factor influencing the conception of the HCB.

The major difficulty in satisfying the deflection limit state with FRP structures is that although these materials have excellent strength characteristics, they still have a relatively low elastic modulus, resulting in less rigidity in the structural members and subsequently larger deflections. As a result, the design of these structures for civil applications generally requires an excessive amount of material over what is required to meet the strength limit states. Subsequently, all economy is lost. The embodiment of the HCB uses lesser expensive concrete and steel to meet the deflection limit state. Based on bridges built to date, serviceability still governs design of the HCB, but the over-design for strength is substantially reduced over that of a homogenous FRP beam, resulting in a more economical structure. In fact, it would be possible to force the bending strength limit state to control design simply by using lower grade steel for the tension reinforcing. However, currently there is no compelling reason to switch to lower strength steel.

It is important to note that in most conventional concrete bridge structures the cross-sections of the girders are prismatic, i.e. constant over the length of the beam. For simply supported beams, this grossly simplifies deflection calculations. Where cross-sectional properties vary over the length, the assumption of a constant flexural rigidity (EI) over the length is no longer valid. Variation in the rigidity over the length of the beam has to be taken into account, even for simply supported beams. Such is the case with the HCB.

In order to account for the variable location of the compression strut along the length of the beam, the section properties for the HCB are generally calculated at 1/10th points along the length. The Moment Area Theorem is used to calculate the deflection of the beam at mid-span performing a numerical integration of the controlling live load moment diagram and the variable section properties. This results in very accurate calculation for simply supported structures. For continuous structures it is still easier to calculate the live load deflections using a matrix analysis or finite element program.

The deflected shape of a simply supported beam is depicted in Figure 2.2. The slope of the tangent to the deflected shape from the left end of the beam can be calculated as follows:

$$\theta = \int \frac{M(x)dx}{EI}$$

The distance between the tangent line at the centerline and the bottom of the deflected beam can be calculated as follows:

$$\delta_i = \int \frac{xM(x)dx}{EI}$$

At the centerline of the beam, the deflection of the tangent is:

$$\delta_{x/L} = \frac{\delta_1}{2}$$

The actual deflection at the centerline of the beam is:

$$\delta_{CL} = \delta_{x/L} - \delta_i$$

The deflection at any other point along the beam is:

$$\delta_j = \frac{x\delta_1}{L} - \delta_{x/L}$$

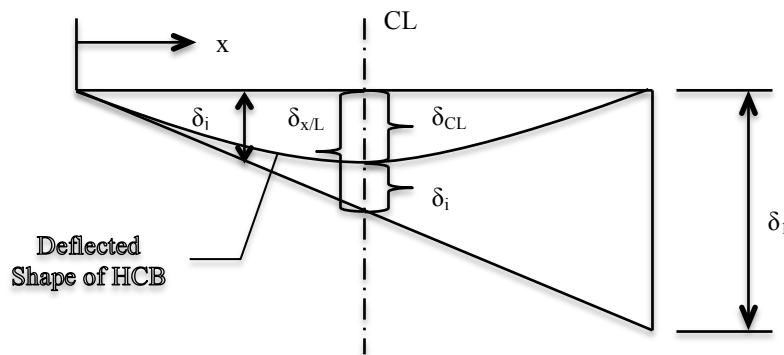

Figure 2.2 Deflected Shape of Simply Supported Span

Although the moment area theorem provides the exact answer, the live load envelope seldom follows a smooth function. Further, because of the curvature of the compression reinforcing in the arch, the moment of inertia varies along the length of the beam as a function of distance from the left support “x”. Subsequently, it is still generally easier to do a numerical integration than to perform the closed form integration.

Once the deflection value is calculated, it should be checked against the respective code specified value. The deflection criteria for specific applications addressed in the design spreadsheet come from the various design codes previously mentioned. In most codes the allowable deflection is a function of the span length “L”. The values shown below assume the span length “L” is represented in units of inches.

- L/360 – Typical for building structures
- L/800 – AASHTO criteria for bridges
- L/1000 – AASHTO criteria for bridges with pedestrian sidewalks
- L/640 – AREMA criteria for steel and prestressed concrete railway bridges

In evaluating structures for live load deflections, only service level (unfactored) live loads should be considered in the deflection calculation. This is the case regardless of whether the design is being conducted using WSD or USD. In many cases it is still necessary to include the impact factors applied to the live loads, which are different from load factors. One side note regarding deflections is that this limit state was actually established to limit live load dynamic behavior of the structure. The allowable static live load deflections were derived in order to provide enough stiffness to the overall structure to control undesirable dynamic behavior. The limiting values were established based on subjective evaluations by people standing on the structures and have remained unchanged for decades.

2.3 POSITIVE MOMENT BENDING

Bending failure is undoubtedly one of the more critical strength limit states. For the HCB, the ultimate bending limit state is analogous to a reinforced concrete beam in many ways. In evaluating the ultimate strength design of reinforced concrete it is assumed that the concrete below the neutral axis has cracked, is in tension and no longer contributes to the strength of the beam. Plane sections are assumed to remain plane, but the stresses in the concrete are not linearly proportional to strain at ultimate. Although the HCB contains materials that are generally new to most practicing structural engineers, with a basic understanding of the mechanics of Bernoulli-Euler beam theory and a working knowledge of standard bridge design codes, it is not difficult to assess the load carrying capacity of the HCB. In fact most design codes, including AASHTO and AREMA are compartmentalized and allow the engineer a fair amount of flexibility in assessing how forces are resisted by a structure. Further, the applied loads as well as the load and resistance factors can easily be rationalized for assessing the response and structural capacity of the HCB.

For simplification in calculations, it is assumed that at the ultimate strain, the concrete stress remains constant over the entire depth in compression. The magnitude of this constant stress is assumed to be some portion of the ultimate compressive stress in the concrete. The most commonly used value in the United States is the limiting value of $0.85f_c'$, where f_c' is the strength of the concrete determined from test cylinders. This equivalent stress is then applied over a depth, “a” which is some portion of the total depth of concrete above the neutral axis. This limiting stress applied over the specified depth results in a compression force that is equivalent to what would be found from a rigorous integration of the actual stresses in the concrete loaded in compression. Although there are several models that have been derived for this purpose, the one described above is commonly known as “Whitney’s Equivalent Stress Block”, and can be found in most reinforced concrete textbooks.

By assuming the compressive stress in the concrete at failure, it is possible to ascertain the amount of tension reinforcing required for a concrete beam by equilibrating the tension force with the compression force in the concrete. A balanced design and subsequently a ductile failure mode are assured in reinforced concrete beams by limiting the amount of the reinforcing steel such that the steel will yield prior to crushing of the concrete. When the failure mode becomes crushing of the concrete, the beam is considered to be over reinforced.

As mentioned before, the amount of tension reinforcing required for the HCB is typically governed by satisfying the deflection criteria. As a result, whether steel, glass or carbon is utilized for the tension reinforcing, in most cases all of the materials except the compression reinforcement will remain in the elastic region. As a result, at ultimate bending capacity, the failure mode for the hybrid-composite beam is likely to be crushing of the compression reinforcement rather than a ductile failure of the tension reinforcement or failure of the laminate. Noting these differences, it is now possible to describe the methodology in calculating the ultimate bending capacity of the HCB.

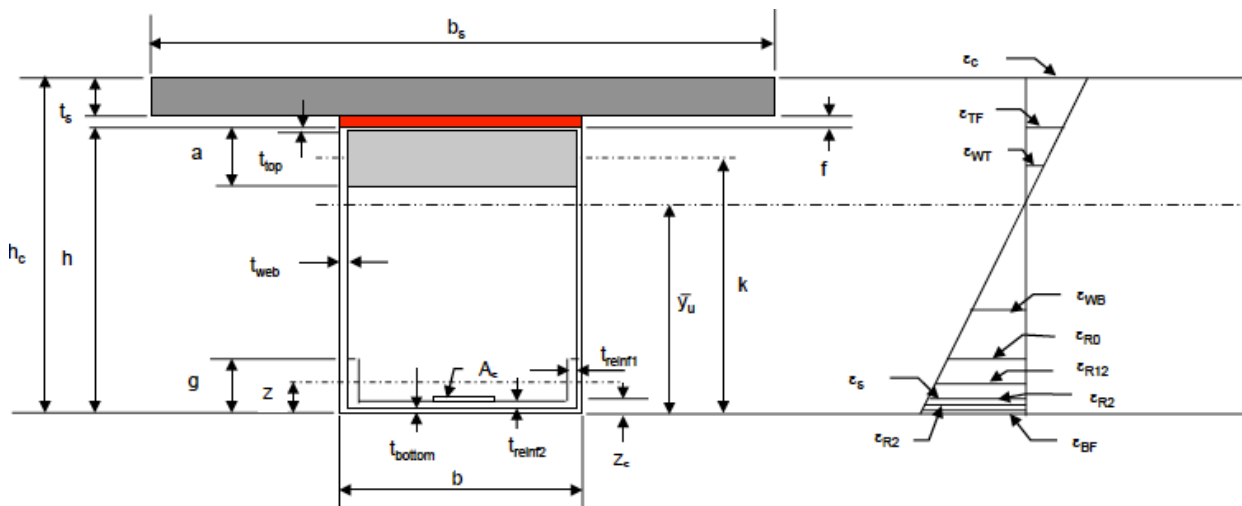

Figure 2.3 Typical HCB Cross-Section & Strain Diagram

The typical cross-section for an HCB along with the strain components of the various elements of the beam can be generically defined by the drawing in Figure 2.3. Based on these assumptions it is possible to ascertain the strain in each component of the beam using strain compatibility. The various components of the HCB are defined by the following dimensional variables:

Dimensional Variables

<u>Variables</u>	<u>Dimension</u>	<u>Description</u>
h_c	Inches	Total depth of composite section (deck and fillets inclusive)
b_{eff}	Inches	Effective slab width of composite concrete deck
h	Inches	Depth of HCB
a	Inches	Depth of compression reinforcement, a.k.a. Arch (trial value approximately $h/8$)
b	Inches	Width of HCB shell
b'	Inches	Width of compression reinforcement (Arch)
z	Inches	Distance to centroid of side reinforcement relative to bottom of beam (optional)
g	Inches	Height of side reinforcement (optional)
k	Inches	Distance from bottom of beam to centroid of compression reinforcement
t_{top}	Inches	Thickness of FRP shell top flange (input in layers)
t_{bottom}	Inches	Thickness of FRP shell bottom flange (input in layers)
t_{rein2}	Inches	Thickness of supplemental tension reinforcing along bottom flange (input in layers)
t_{rein1}	Inches	Thickness of supplemental tension reinforcing side return (input in layers)
t_{web}	Inches	Thickness of FRP shell webs (input in layers)
A_s	in^2	Area of steel reinforcement (typically prestressing strand)
z_s	Inches	Distance to centroid of steel reinforcement relative to the bottom of beam
t_s	Inches	Thickness of composite concrete deck
f	Inches	Minimum fillet height (fillets neglected in section property calculations)

The strain in each individual component can be derived using similar triangles based on a prescribed value for the strain in the top fiber of the concrete, " ϵ_c ". The equation for each component of an HCB acting compositely with a concrete deck is shown below.

The strain in the Top Flange of HCB shell:

$$\epsilon_{TF} = \epsilon_c \frac{h - \bar{y}_u}{h_c - \bar{y}_u}$$

The strain in the top portion of the HCB shell webs in compression:

$$\epsilon_{WT} = \epsilon_c \frac{h - \bar{y}_u}{2(h_c - \bar{y}_u)}$$

The strain in the bottom portion of the HCB shell webs in tension:

$$\epsilon_{WB} = \epsilon_c \frac{-\bar{y}_u}{2(h_c - \bar{y}_u)}$$

The strain in the bottom flange of the HCB shell:

$$\epsilon_{BF} = \epsilon_c \frac{-\bar{y}_u}{(h_c - \bar{y}_u)}$$

The strain in the fabric tension reinforcing (typically steel or carbon) along bottom of the HCB shell:

$$\epsilon_{R2} = \epsilon_c \frac{t_{bottom} + t_{rein2}/2 - \bar{y}_u}{(h_c - \bar{y}_u)}$$

The strain in the side return portion of fabric tension reinforcing (typically steel or carbon) of the HCB shell:

$$\epsilon_{R11} = \epsilon_c \frac{g - \bar{y}_u}{(h_c - \bar{y}_u)}$$

The strain in the triangular portion of the fabric tension reinforcing side return:

$$\epsilon_{R12} = \epsilon_c \frac{\frac{1}{2}(g - t_{bottom} - t_{reinf2}) - \bar{y}_u}{(h_c - \bar{y}_u)}$$

The strain in the steel tension reinforcing:

$$\epsilon_s = \epsilon_c \frac{z_s - \bar{y}_u}{(h_c - \bar{y}_u)}$$

The stress in each component of the HCB can then be calculated by multiplying the strain values by the respective moduli of elasticity values for each material using the following equation for Hooke's Law, where "i" signifies the component under consideration:

$$\sigma_i = E_i \epsilon_i$$

The force in each component of the beam can then be calculated by multiplying the stress times the respective area for each component using the equations below starting with the deck slab. The compression force in the composite concrete deck is calculated assuming that the compressive strain in the concrete ϵ_c has reached an ultimate compressive strain $\epsilon_c = \epsilon_{cu} = 0.003$ using the following equation:

$$F_{CS} = 0.85 f'_{cs} \beta_1 t_s b_{eff}$$

Where f'_{cs} is the ultimate compressive stress of the deck concrete. This equation holds true where the plastic neutral axis is located below the deck slab. However it is possible for the location of the neutral axis to be located within the deck slab itself, in which case the force in the deck becomes:

$$F_{CS} = 0.85 f'_{cs} \beta_1 x b_{eff}$$

Where β_1 is 0.85 for $f'_{cs} = 4,000$ psi concrete and a variable $x = h_c - \bar{y}_u$. The value of $\beta_1 x$ defines Whitney's equivalent stress block as is common in reinforced concrete design. The value of β_1 is a function of the ultimate concrete strength.

The compression force in the arch concrete also depends on the location of the plastic neutral axis or PNA. In the case where the PNA falls below the concrete arch concrete, the force in the arch is calculated as follows:

$$F_{CB} = 0.85 f'_{CB} \beta_1 a b'$$

Where f'_{CB} is the ultimate compressive stress in the arch concrete. In the case where the PNA is located within the concrete deck slab, it is assumed that the arch goes into tension and subsequently the force in the arch is set to zero. The other condition is where the PNA is located within the arch, in which case the force in the arch concrete is limited to the concrete above the PNA that is in compression and is thus calculated as:

$$F_{CB} = 0.85 f'_{CB} (\beta_1 x - t_s) b'$$

The other components of the HCB are calculated as a function of the strain in the concrete. The compression force in the FRP top flange of the HCB shell is calculated as follows:

$$F_{TF} = E_{TF} \epsilon_c \frac{h - \bar{y}_u}{h_c - \bar{y}_u} b t_{top}$$

The compression force in the portion of HCB shell webs located above the plastic neutral axis:

$$F_{WT} = E_w \epsilon_c \frac{h - \bar{y}_u}{2(h_c - \bar{y}_u)} t_{web} (h_c - \bar{y}_u)$$

The tension force in the portion of HCB shell webs located below the plastic neutral axis:

$$F_{WB} = E_w \epsilon_c \frac{-\bar{y}_u}{2(h_c - \bar{y}_u)} t_{WB}(\bar{y}_u)$$

The tension force in the FRP bottom flange of the HCB shell:

$$F_{BF} = E_{BF} \epsilon_c \frac{-\bar{y}_u}{(h_c - \bar{y}_u)} b t_{bottom}$$

In some cases, supplemental tension reinforcing can be added that has both a bottom flange and a side return component. This type of reinforcing could be carbon or steel fibers or some other type of fabric reinforcing. In many cases, this element of tension reinforcing is omitted in which case the respective force contributions are zero. For simplicity of calculation, the force in the side returns is quantified as a constant stress (rectangular) portion of the stress trapezoid. The other portion is a triangular stress distribution. The force in the bottom flange portion of this supplemental tension reinforcing is calculated as follows:

$$F_{R2} = E_{R2} \epsilon_c \frac{t_{bottom} + t_{reinf2}/2 - \bar{y}_u}{(h_c - \bar{y}_u)} b t_{reinf2}$$

The tension force in the portion of the supplemental reinforcing with a constant (rectangular) stress component is as follows:

$$F_{R11} = E_{R2} \epsilon_c \frac{g - \bar{y}_u}{(h_c - \bar{y}_u)} 2 t_{reinf1} (g - t_{bottom} - t_{reinf2})$$

The tension force in the portion of the supplemental reinforcing with a triangular stress component is:

$$F_{R12} = E_{R2} \epsilon_c \frac{(g - \bar{y}_u) - [\frac{1}{2}(g - t_{BOT} - t_{reinf2}) - \bar{y}_u]}{(h_c - \bar{y}_u)} [2(t_{reinf1})(g - t_{bottom} - t_{reinf2})]$$

In some cases, the supplemental tension reinforcing can be steel fabric. In this case, if the strain in the steel exceeds the yield strength of the material, the force is limited to a stress calculated based on the yield strength of the steel used. If this supplemental tension reinforcing is FRP and the limiting strain is exceeded, the forces in these components are set to zero as the FRP materials are generally linear elastic to failure and then carry no additional load after rupture.

The last component of the beam is the tension reinforcing, which is typically steel. The force in this component is calculated as follows:

$$F_s = E_s \epsilon_c \frac{z_s - \bar{y}_u}{(h_c - \bar{y}_u)} A_s$$

Again, if the strain in the steel tension reinforcing exceeds the yield strain of this material, then the force in the steel is calculated using a limiting stress equal to the yield strength of the steel. Hence the force in the steel becomes:

$$F_s = f_y A_s$$

Where f_y is the yield strength of the steel being used.

Once all of the horizontal force components in the HCB are known, the exact location of the plastic neutral axis can be found directly from force equilibrium on the section with the simple equation:

$$\Sigma F = F_{CS} + F_{CB} + F_{TF} + F_{WT} + F_{WB} + F_{BF} + F_{R2} + F_{R11} + F_{R12} + F_s = 0$$

By definition, the HCB has several different materials each with different constitutive properties. To simplify the calculations, it is easiest if all the materials are normalized to the constitutive properties of one material. Historically, the

best solution has been to normalize all the materials to the properties of the glass FRP laminate in the HCB shell. This is the philosophy typically followed for the deflection calculations as well, where all of the section properties are calculated based on dimensions normalized by the ratios of Young's modulus of elasticity for a given material to that of the FRP laminate as follows:

$$n_c = \frac{E_{concrete}}{E_w} = \text{Modular ratio of concrete to FRP webs}$$

$$n_R = \frac{E_{reinforcing}}{E_w} = \text{Modular ratio of supplemental tension reinforcing to FRP webs}$$

$$n_s = \frac{E_{steel}}{E_w} = \text{Modular ratio of steel tension reinforcing to FRP webs}$$

In general it is usually assumed that the laminate in the FRP shell is relatively constant, in which case:

$$E_{TF} = E_{BF} = E_w$$

Subsequently, all calculations are made using the modulus of elasticity of the FRP webs. It should be noted however that although this is an acceptable assumption to calculate strains, the proper modular ratios must still be used in calculating the actual stress in each given material.

Knowing all of the force equations for each component and normalizing each component to the properties of the FRP shell, it is now possible to return to the force equilibrium equation and solve directly for the plastic neutral axis using the following equation:

$$\bar{y}_u = \frac{[bt_{top}h + t_{web}h^2 + \frac{0.85h_c(f'_c t_s b_{eff} + f'_{CB} ab)}{E_w \epsilon_c} + 3n_R t_{Reinf1} g^2 + n_s z_s A_s]}{[bt_{top} + 2t_{web}h + \frac{0.85(f'_c t_s b_{eff} + f'_{CB} ab)}{E_w \epsilon_c} + bt_{bottom} + n_R b t_{Reinf2} + 2n_R t_{Reinf1} g + n_s A_s]}$$

The closed form solution offered above is based on the assumption that the PNA is below the arch concrete. As noted previously, if the PNA is within the arch concrete or within the deck slab, the force components for these elements need to be revised accordingly. The subsequent derivations are left to the reader. For simplicity, the same calculation is performed in a spreadsheet calculation. In the programmed version, the user assumes a location for the PNA, the program then calculates the corresponding strains and forces. If the sum of the horizontal forces within the section is not in equilibrium, the program assumes a new location for the PNA. This calculation sequence is repeated until the program converges on and PNA location that results in internal equilibrium.

Once the exact location of the PNA has been established, the nominal moment resistance capacity can be calculated by summing the moments around any point in the cross-section. For simplicity, the PNA can be used as the point to sum moments about. Subsequently, the equations for the respective moment arms for each component of the HCB about the PNA can be defined as follows:

$$d_{CS} = -(h_c - \bar{y}_u - \frac{t_s}{2})$$

$$d_{CB} = -(h - \bar{y}_u - t_{top} - \frac{a}{2})$$

$$d_{TF} = \bar{y}_u - (h - \frac{t_{top}}{2})$$

$$d_{WT} = -\frac{2}{3}(h - \bar{y}_u)$$

$$d_{WB} = \frac{2}{3}(\bar{y}_u)$$

$$d_{BF} = \bar{y}_u - \frac{t_{bottom}}{2}$$

$$d_{R2} = \bar{y}_u - t_{bottom} - \frac{t_{R2}}{2}$$

$$d_{R11} = \bar{y}_u - 1/2 (g + t_{bottom} + t_{R2})$$

$$d_{R12} = \bar{y}_u - g/3 - 2/3 (t_{bottom} + t_{R2})$$

$$d_s = \bar{y}_u - z_s$$

In addition to the typical resistance factor of 0.9, the resistance is also multiplied by an additional 0.9 Φ factor as suggested in ACI 440 to compensate for knock down factors on FRP laminates. The calculated nominal moment capacity is compared to the factored demand to validate that the section has adequate capacity. The equations are valid for any section and typically the capacity is checked at 1/10th points for the HCB without the concrete slab. For the maximum moment with the composite concrete deck, the section is typically only checked at mid-span. This is based on the fact that once the deck is cast on top of the beam, assuming the amount of steel remains constant along the length of the beam, then the bending capacity at other points along the beam is essentially constant.

The rigorous calculation detailed above provides an accurate and rational method of calculating the bending strength capacity of the HCB consistent with generally accepted structural design codes and specifications. Alternatively, one can generally get an approximate answer within 5% to 10% of the exact answer, simply by taking the compression force in the concrete, i.e. the slab and/or arch, and equilibrating it to a tension force in the steel, or in other words, the nominal moment capacity of the section is as shown in the following question:

$$\phi M_n = C(d - a/2)$$

$$\Phi M_n = C(d - a/2)$$

Where: Φ = resistance factor for bending

M_n = nominal moment capacity

$C = f_c' ab$ (the compression force in Whitney's equivalent stress block)

d = the distance from the centerline of the steel reinforcement to the top of the beam

a = the depth of concrete in compression

Although in the case of a compression strain failure of the concrete, the HCB no longer conforms to the elusive, slow ductile failure mode, it should be noted that there are not very many documented cases of this failure mode resulting in a collapse in real life structures. For cases where it is deemed necessary or desirable, there are ways to create this ductile, tensile failure in the HCB. For example, by using a lower grade steel, supplementing lower grade steel for deflections only or when possible simply by building multi-span bridges where the HCB is made continuous for live load by providing negative moment reinforcing steel over the supports as has been done on several structures to date.

2.4 NEGATIVE MOMENT BENDING

Although originally conceived as a simply supported member, the HCB can also be made continuous for live loads. This is done by placing negative moment reinforcing steel in the deck over the piers and diaphragms. The calculation of the resistance is conducted in much the same manner as for positive bending, but with the strain diagram reversed to reflect tension stresses in the top of the section and compressive stresses in the bottom of the section.

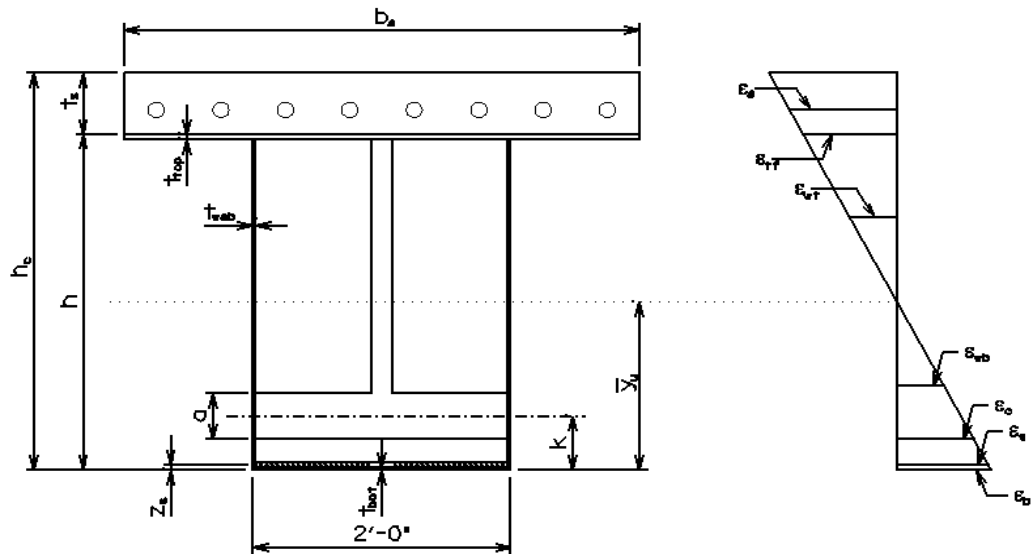

Figure 2.4 – Strain Distributions for Negative Bending

For sections directly over the piers, the strain components in the FRP shell and strands can be completely discounted and the negative bending capacity is no different than for a conventional reinforced concrete beam where the arch is the compression block and the rebar in the deck is the tension reinforcing. For sections away from the supports, the resistance can be checked assuming some contribution from the FRP shell. In most cases, the HCB has sufficient capacity that even if a plastic hinge is formed over the intermediate piers, the HCB still has adequate capacity to carry the specified loads as a simply supported beam.

2.5 VERTICAL SHEAR

Similar to concrete and steel, shear behavior of the HCB is a bit more complex than bending. In the HCB, shear resistance is facilitated by three mechanisms acting in concert. To start with, the primary reason for the arch shape of the compression reinforcing in the HCB is to carry a significant portion of the shear as direct compression forces down to the thrust line and into the bearings. Another significant component of the shear mechanism is that the quad-weave fabrics in the HCB shell provide tremendous shear capacity due to the +/- 45 degree plies in the laminate. Finally, the third mechanism involves a thin concrete web (typically on the order of 3 inches) that extends vertically along the longitudinal centerline of the beam between the top of the arch and the bottom of the supported deck. This concrete web is actually monolithic with the arch concrete when cast. Further, the diagonal shear connectors extending from the arch to the deck provide for very efficient reinforcing of this concrete web.

The composite action between the HCB and the supported deck is facilitated through the shear connection device that is comprised of galvanized reinforcing bars spaced at typical intervals of roughly 12 inches. These bars are placed at 45-degree angles and have a 90-degree hook at both ends. One of the hooks is connected under a continuous ½ inch diameter steel strand lying in the bottom of the arch rib. The other hook is developed into the concrete deck. These shear connectors are basically designed like inclined stirrups in a reinforced concrete beam, with the number of connectors being sufficient to develop the full factored moment acting on the section in bending. The fragmentary perspective in Figure 2.5 provides a schematic detailing all of the main components of a typical HCB.

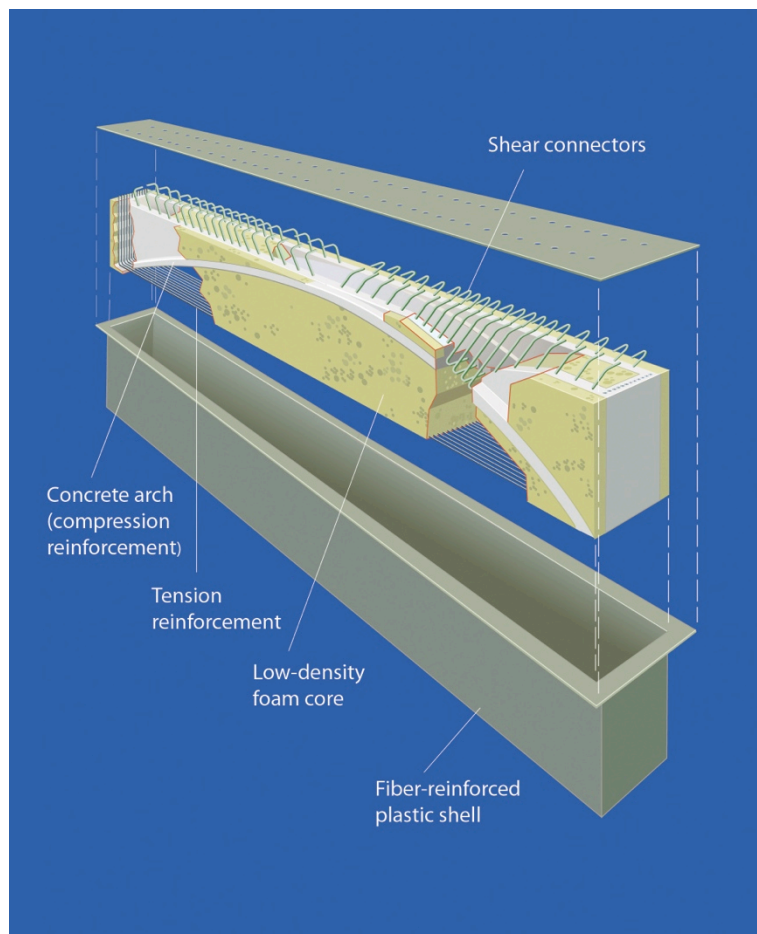

Figure 2.5 - Fragmentary Perspective of a typical HCB

In quantifying the shear resistance of the HCB, the first component to consider is the thrust in the arch at a given section. The thrust can then be discretized into horizontal and vertical components. The vertical component can be deducted from the gross shear on the section as the arch is resisting this. The remaining shear is then resisted primarily by the FRP webs, but also by the thin concrete web above the arch. This results in a hybrid resistance to the shear forces in the beam, but there are some other interesting facets of the shear behaviour that very much emulate a reinforced or prestressed concrete beam. For example when the loads are applied to the structure to produce maximum shear effects, e.g. adjacent

to a support, the majority of the shear is resisted strictly through the arching action similar to the strut and tie behavior (Collins, et.al. 2008).

Further, because the principal stresses in the beam are oriented along the arch and there is no concrete within the tensile zone of the beam to crack, in essence the concrete cannot crack and as a result it is not necessary to rely on Modified Compression Field Theory (MCFT). Instead of relying on steel reinforcing in the concrete, the horizontal shear between the arch and the tension reinforcing is carried by the FRP laminate and since the laminate is bonded to the foam core along a continuum, it is possible to develop the full capacity of the FRP laminate up to the factored shear demand. This behaviour has been validated in numerous laboratory tests on prototype beams for each installation of the HCB done to date.

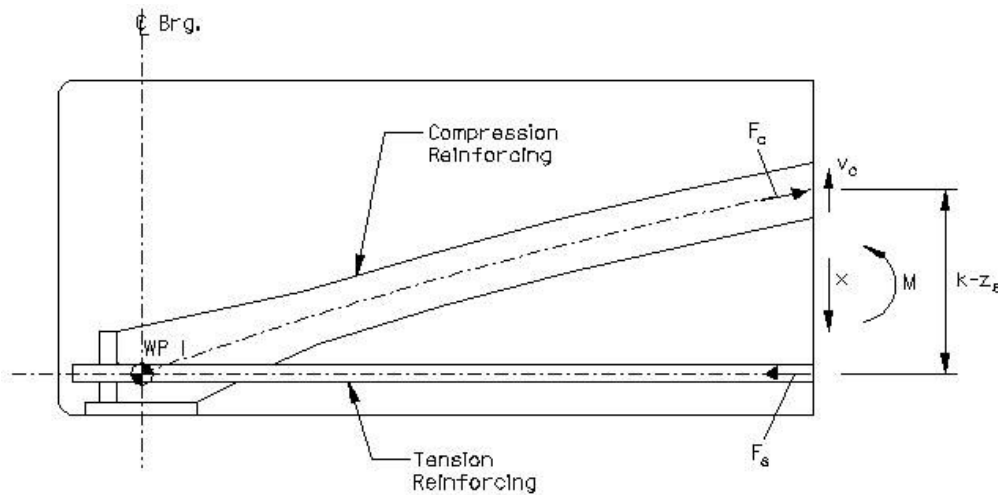

Figure 2.6 - Free Body Force Diagram Showing Shear Component in Compression Reinforcing

The free body diagram shown in Figure 2.6 demonstrates evaluating the reduction in the shear force in the webs of the HCB. This figure shows the internal forces acting on the compression and tension reinforcing. The component of shear taken by the compression reinforcing is V_c . The magnitude of V_c is calculated by dividing the moment at this section by the moment arm ($k-z_s$) to get the axial force in the tension reinforcing, which is equal to the horizontal component of the force in the compression reinforcing. Knowing the slope of the compression reinforcing at the given location, it is then possible to calculate the vertical component, V_c , of the resultant compression force. As the profile of the compression reinforcing is a continuous parabolic arch, it is easy to calculate the slope of the compression reinforcing at any given point by simply taking the first derivative of the continuous function for the profile of the arch. The equation for calculating the net shear on a section then becomes:

$$V_{net} = V - M \frac{k'}{(k - z_s)}$$

In this equation (k') is the slope of the profile at the given location. It is important to note that due to the nature of moving loads, an accurate calculation for the net shear requires that the moment used in this equation be calculated for the same position of the live load that is used for calculating the shear, i.e. corresponding moments and shears. It is also important to note that the reduction in web shear force due to arching action is also predicated on the assumption that there is no shear or bending in the compression reinforcing, i.e. it is in pure compression and the resultant compression force is coincident with the profile of the arch.

2.6 HORIZONTAL SHEAR

In most cases it is desirable to engage composite action between the deck slab and the HCB for the significant increase in bending stiffness and subsequent reduction in live load deflections. Depending on the specific project, composite action between the deck and HCB may also be required for bending strength. Regardless, some rational basis for the design limit state of this reinforcing is required. The methodology created for the shear transfer between the beam and the

overlay also provides for a positive method of connection between the beam and overlay. This device is even more important in bridge applications where the beams are made composite with the supported concrete deck for strength purposes as well as satisfying deflections.

The shear connectors used to connect the deck to the HCB are typically galvanized reinforcing bars placed on a 45 degree incline with one end embedded in the concrete of the compression arch and the other end embedded in the concrete slab. A schematic view of a series of shear connectors in an HCB can be seen in the cut-away elevation of half a beam as shown in Figure 2.7. The embedding of the shear connectors in the arch and slab results in a very efficient use of the shear connector as a tension member. The compression forces in the slab are transmitted into the shear connector and transferred directly into the compression arch where they are carried to the bearings as depicted in the strut and tie model shown in Figure 2.8. This load path does not require any of the compression force in the slab to be transmitted as shear forces in the FRP webs.

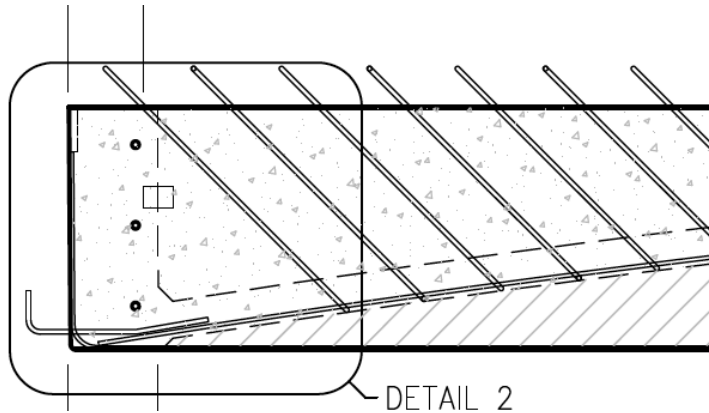

Figure 2.7 - Cut-Away of Beam Elevation with Shear Connectors

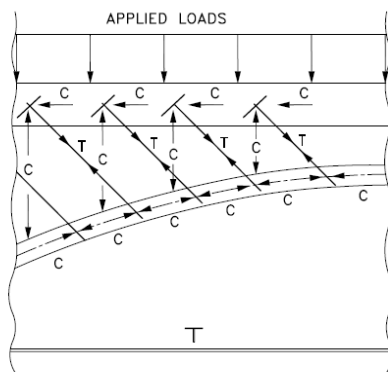

Figure 2.8 - Strut-and-Tie Model of Shear Stud Behavior

Although the shear connector for the HCB serves the same purpose as the shear connectors in conventional beams, the fact that it is positioned on a 45 degree angle results in a slightly different behavior. Regardless, the shear-friction design method contained in Article 11.7.4 of ACI-318 provides a rational method of quantifying the shear strength of this type of connection device. Using equation (11-27) from this section we get:

$$V_n = A_{vf} f_y (\mu \sin \alpha_f + \cos \alpha_f)$$

Where: V_n = nominal shear capacity of one connector

A_{vf} = shear area of one connector

f_y = yield strength of shear connector

μ = coefficient of friction between top of HCB flange and concrete overlay (anticipated to be similar to concrete anchored to as-rolled structural steel, or 0.7 for normal weight concrete)

α_f = angle between shear-friction reinforcement and shear plane

Whereas this equation quantifies the shear capacity of a single connector, the number of connectors required for ultimate strength would be determined in accordance with the provisions of Article 10.38.5.1.2 in the AASHTO Standard Specification for Highway Bridges. In this provision it is assumed that the number of shear connectors provided must be sufficient to develop the total ultimate compression force in the supported concrete slab. It also assumes that all of the connectors will have reached their ultimate capacity in order to develop the compression force in the slab.

It should be noted that two other criteria need to be evaluated in order to quantify the shear capacity of the connectors including; the compression failure cone of the concrete located around the anchorage of the stud as well as the fatigue capacity of the stud assembly under the requisite number of live load cycles. In most cases, the shear connectors used for the HCB comprise conventional rebar with a 90-degree hook at both ends for development. The hook on the lower end is developed around a piece of strand draped along the bottom of the arch concrete. The hook on the top end is tied into the deck steel for the structural concrete slab. Subsequently, the shear connectors behave more like conventional, horizontal shear reinforcing steel than shear studs on a steel beam. Laboratory testing done to date appears to indicate that the shear connectors are adequately designed and developed to resist the anticipated forces and that fatigue loading does not compromise the capacity.

2.7 FATIGUE CONSIDERATIONS

To date, extensive fatigue testing has been performed on at least five laboratory specimens as well as a complete railroad bridge subjected to real Class 1 freight rail traffic. These specimens have been subjected to anywhere between 500,000 to 2,000,000 cycles of fatigue without any change in performance. In particular, the first 30-foot railroad bridge tested in Pueblo, CO was subjected to 237 Million Gross Tons (MGT) of heavy axle Class 1 traffic (this equates to roughly 1,500,000 cycles of service load Cooper E-80 loading).

In evaluating the behavior of the HCB for fatigue, consideration should be given both to materials as well as the interface between the major components of the beam. Regarding the compression reinforcing, the concrete in the HCB is essentially in compression at all times. Concrete in compression is not subject to fatigue failures. The FRP laminates and the steel tension reinforcing are subjected to tensile stresses. However, in most applications to date, the live load, tensile stress ranges in these materials are on the order of 10% of the ultimate capacities. Subsequently, there currently appears to be no cause for concern regarding fatigue in the FRP or the steel tension reinforcing.

One exception to this matter is when the design allows for omitting steel for the tension reinforcing and just using additional glass fabric for the tension capacity. This has been done successfully on a couple of different occasions. However, when this is the case, the limiting sustained stress levels in the laminate due to sustained dead loads should be limited to within 25% of the ultimate capacity to prevent creep rupture.

Lastly, there is the overall system consideration of what happens between the interfaces for the various materials. Again, all fatigue cycling conducted to date tends to dismiss any concern for hysteresis that could result in an overall change in the stiffness of the system due to breaking down the interfaces between the different materials.

2.8 LOAD RATING METHODOLOGY

Load Rating for an HCB highway bridge can be performed using the standard methodology and equations published in the AASHTO Load and Resistance Factor Rating Specifications (LRFR) for both inventory and operating conditions. These ratings are typically done for the ultimate bending limit state. As discussed previously, the shear limit state still requires further evaluation to develop an accurate mathematical model for predicting the failure limit state for shear. In the interim, load tests in the laboratory have consistently indicated shear capacities well beyond two times the code specified factored demand.

3.0 MATERIAL & STRUCTURAL DAMAGE SERVICEABILITY CONSIDERATIONS

This section of the manual is intended to provide information relative to some types of material and structural damage that could result from environmental conditions or other potentially catastrophic events that are not necessarily addressed in the codes. These items include things like UV degradation of the laminates, fire resistance, thermal loads and lateral impact. The information provided is primarily to make the owner aware of conditions that could impact the long-term performance of the HCB and where practicable, provide suggestions for mitigation if one of these issues is encountered during the service life of the HCB Bridge.

3.1 ULTRAVIOLET RADIATION

Solar ultraviolet (UV) radiation exposure is known to be deleterious to organic materials, including polymer resins. There is some evidence that the effect of UV radiation may be limited to cosmetic degradation of the resin in the surface of the laminate and that there is no impact to the structural properties of the FRP laminate. In some ways this is no different from a thin layer of patina that might form on weathering steel.

Visual evidence of degradation from UV radiation can be observed by change in the surface color, loss of pigment and/or loss of luster to the surface of the laminate. Although the degradation is generally confined to a thin layer on the surface, studies have been conducted to quantify the degradation of bulk tensile properties in a vinyl ester matrix (Signor, Chin). The degradation on the resin usually manifests itself as a decrease in the ultimate strain and a decrease in the specific toughness of the surface layer of the resin. This results in an increase in the surface modulus of elasticity combined with a greater propensity for the propagation of cracks in the surface. Consequently, given the inevitable exposure of a bridge girder to UV radiation, it would be undesirable to leave the surface layer of the laminate exposed to sunlight.

Additives have been included in the resin formulations to help stabilize the resins against UV degradation. Another common method to mitigate UV concerns that also enhances the aesthetic appearance is the application of a gel coat. A gel coat is a thick resin layer on the exterior surface of the laminate that can be sprayed into the mold prior to lay-up and infusion of the laminate. The gel coat can also be spray or roller applied subsequent to the manufacturing of the composite. The gel coat is typically a different type of resin than that used for the matrix of the FRP laminate, but the gel coat resins are usually formulated to be compatible with specific resins. In addition to the UV protection and improved surface finish, the gel coat also serves as an excellent surface barrier against moisture intrusion and enhances the fire resistant and/or flame spread qualities of the FRP laminate.

The standard practice with HCB bridges fabricated to date is to utilize UV inhibiting admixtures in the pigments mixed in with the resin. In addition, a post-applied gel coat paint is generally rolled onto any fascia beams or other surfaces that are anticipated to receive direct sunlight. Unlike steel, the substrate under the gel coat will not rust. Subsequently, it is not anticipated that the gel coat will need to be removed and reapplied on a periodic basis. Regardless, the surface should be checked during biennial inspection to look for any loss of bond, or peeling that might warrant reapplication. Note that failure to repair the gel coat surface constitutes more of a cosmetic issue than any concern for accelerated deterioration of the laminate. The UV inhibiting pigments are still contained in the resin and although the surface may fade and become chalky, the strength of the laminate should not be compromised.

3.2 FIRE RESISTENCE

One question that continually arises regarding composites relates to the susceptibility of fire damage. The threat of fire for bridges generally ranges somewhere between an errant brush fire to a tanker truck exploding on, or underneath a bridge. Given the range of possible fire events, bridge codes have never really committed to quantifying an event that has to be satisfied in design. Regardless, this is a concern for a bridge owner and subsequently this issue has been investigated to determine measures that could help mitigate the severity of these events. Although not addressed in bridge codes, fire resistance does become a significant issue in building structures or other occupied spaces.

When required, quantification of fire test response is usually determined through ASTM E84-05 “*Standard Test Method for Surface Burning Characteristics of Building Materials*”. The HCB’s fabricated to date have all been infused using a Bisphenol-A, Epoxy Vinyl Ester resin that is generally combined with styrene to lower the viscosity for infusion. In a nutshell, these resins will burn with a sustained ignition source applied. Whereas it is almost impossible to fabricate a bridge structure that can resist any fire event, the resins can be formulated with Bromine or Aluminum Tetra hydrate to at least develop self-extinguishing characteristics that will reduce the likelihood of burning unless a continuous ignition source is applied. Although these additives will help facilitate self-extinguishing properties for the laminate, they can make the infusion process more difficult due to changes in the viscosity of the resin.

Another test related to fire resistance is ASTM E119 “*Standard Test Method for Fire Tests of Building Construction and Materials*”. The purpose of this test is to look at the ability of a structural system to contain a fire or to retain its structural integrity, or both, during the test and to measure the endurance of the system in time. Again although this test has been used to quantify the performance of building structural systems since 1918, there are no prescribed endurance limits for bridge structures.

In any case, it should be noted that 90% of the strength and stiffness of the HCB still comes from concrete and steel. Even with an applied heat source, the bridge will likely be able to sustain loads under fire for at least as long as a similarly designed steel girder bridge. It should also be noted that the polyisocyanurate used for the foam core has tremendous R-values on the order of 5.4 hour-sf-⁰F/BTU. In fact the most common application of this product is for thermal insulation. For fires that are confined to the top of a bridge, the HCB’s will also be insulated from the fire by the concrete overlay or deck placed on top of the beams.

3.3 THERMAL EXPANSION

Differential movement due to thermal expansion and contraction is prevalent in all types of structures. The combination of materials in the HCB warrants discussion regarding this topic. In general, the coefficient of thermal expansion (CTE) of an FRP component is highly dependent on the type of resin as well as the type and orientation of the reinforcing fabrics. In pultruded shapes, where most of the reinforcing is in the longitudinal direction, the CTE in the transverse direction can be an order of magnitude different from the CTE in the longitudinal direction. The laminates in the HCB typically use a quad-weave fabric with fibers running in four different directions. As a result, the CTE tends to be very consistent between the transverse and longitudinal directions. Further, ASTM D696 tests were conducted on 14 samples of witness panels fabricated as part of the QC/QA process for the Knickerbocker Bridge to determine the CTE. The average value was found to be approximately 7.0×10^{-6} /deg F. This is almost identical to the CTE’s for concrete and steel. As a result, thermal strains induced in the HCB will not result in any shear between the interfaces of the different materials used. This has also been validated through testing at the University of Maine.

3.4 LATERAL IMPACT

Another issue that comes up quite frequently has to do with the resulting damage that might occur in the event that an HCB bridge is impacted transversely from an over-height vehicle passing under the bridge. Like the issue of fire resistance, this is an issue that is not directly addressed in the AASHTO design codes, but is a legitimate concern. In one study back in 1980, it was documented that about 120 prestressed concrete girder bridges are damaged in the United States each year by impact from over height vehicles (Shanafedt and Horn). Figure 3.1 demonstrates an extreme example of this type of impact. In all likelihood, there are probably even more girders damaged that are not reported. Further, it is likely that an equal or greater number of steel bridges are also impacted each year. Given this frequency of impact, the probability of an HCB bridge being impacted by an over-sized vehicle almost becomes inevitable once a significant number of these bridges have been deployed. The questions that arise are; what kind of damage will be sustained by the HCB for similar impact loads, will an impact load result in collapse of the bridge and how will the HCB damage from an impact be repaired.



Figure 3.1 Photos Showing Prestressed Beam Bridge Impacted by Over-Height Vehicle

The first two questions are not easily answered without experimental data. Vessel and or vehicle collision impact loads applied to bridge substructures are well documented, however there is no specific design load quantified for impact of a bridge girder by an over-height vehicle. In a study conducted at Iowa State University, Abendroth and Fanous performed analytical evaluations of impact loads applied to prestressed concrete girder bridges. As part of this study, impact durations for vehicle crashes were evaluated to arrive at a reasonable load for the analysis. The loads contrived comprised a constant-magnitude force of 120 kips for loads applied directly at a diaphragm location and 60 kips if applied at a location along the bottom of the beam away from a diaphragm. The primary objective of the Iowa State study was to compare the behavior of the bridge under impact loads with steel diaphragms versus concrete diaphragms.

The intent is not to make comparisons between the Iowa State study and the behavior of an HCB bridge, but rather to demonstrate that there is no codified horizontal impact force that must be satisfied prior to deployment of an HCB bridge. That being said, this issue undoubtedly warrants investigation. In general, it is anticipated that the HCB will fair very well under over-height vehicle impact loads due to the highly resilient nature of the FRP laminate. Although the exact nature of the damage from a lateral impact load can only be speculated, Section 5.3 of this report will address how an HCB might be repaired once damage is sustained from vehicle impact.

4.0 CONSTRUCTION DETAILS (PROJECT SPECIFIC)

This chapter is meant to be more project specific with the intent of addressing design, fabrication and construction processes unique to the structure for Bridge B0439. It will also attempt to identify project specific items such as types of bearings, expansion joints, drainage systems or other attached appurtenances as well as assumed fixity and boundary conditions for analysis. For the most part, many of these peripheral elements will not be unique to an HCB bridge, but it will provide the owner with a record of the as-built conditions as well as provide the inspector with additional insight as to what to expect during routine observations.

4.1 FABRICATION DETAILS

As mentioned in earlier sections of this manual, the standard laminate composition of the HCB shell is typically a quad-weave glass reinforcing fabric infused with a vinyl ester resin matrix. More specifically, the following materials comprise the various components of the HCB:

Vinyl ester resin: CCP Stypol 040-8086

Reinforcing layers in HCB webs:

- 1 Layer of surface Veil
- 1 Layer of Continuous Flow Media (CFM)
- 1 Layer of X24 (24 oz/sy, biaxial knit fabric with +/- 45 degree plies)
- 1 Layer of E-QX 10200 (102 oz/sy quad knit fabric with 0, 90 and +/-45 degree plies)
- 1 Layer Shade Cloth (flow transfer medium adjacent to foam)

Tension Reinforcing: ASTM A416 (AASHTO M 230M) 270 ksi galvanized, 7-wire, low-relaxation strand

Shear Connectors: ASTM A615 Grade 60 reinforcing steel, hot-dipped galvanized per ASTM A767

HCB Core: 2 lb/cf density Polyisocyanurate foam (closed cell polyurethane foam)

Adhesives: Weld-On SS230 HV two-part Methyl Methacrylate (MMA)

The fabric reinforcing composition of the top and bottom flanges deviate slightly from the layers identified above and the exact details and layout of every surface of the HCB shell can be found in the shop drawings. The top and bottom flanges are a little less critical once the HCB's have been erected and the arch concrete filled. Once the compression reinforcing has cured almost all of the strength and stiffness for bending are provided by the concrete and steel components. Subsequently damage to the top and bottom flange laminates should not pose any problem with respect to the capacity of the HCB. Regardless, these components should be inspected to make sure that there is no damage that could facilitate degradation to other internal components. This will be discussed in more detail later.

In terms of the FRP shell performance, the webs are a little more critical than the flanges. The layers for the webs have been listed from the outside surface in. The Veil and CFM layers help facilitate resin transfer and provide a resin rich layer on the outside perimeter of the beam shell. Damage to the veil and CFM will not compromise the structural capacity of the beam. These components are not factored into the design calculations, but again, damage to these layers can result in serviceability issues including providing a means of ingress for moisture to enter the structural glass layers.

The resins contain a pigment that includes inhibitors for Ultraviolet (UV) radiation. These inhibitors should prolong the onset of any degradation to the laminate from UV rays. Further, the veil and CFM layers provide an extra layer of protection with respect to UV degradation reaching the structural layers of fabric in the laminates. Bridge B0439 also includes a post-applied gel coat comprised of a UV inhibiting paint that has been roller applied to the exterior surfaces of the fascia beams that are more susceptible to UV radiation. Reapplication of this paint system is not anticipated during the service life of the structure, but it will result in a difference in color between the fascia beams and the interior beams.

The beams for this project were fabricated by Harbor Technologies, Inc. (HTI) in Brunswick, ME, during the time period extending through April-June of 2011. All beams were fabricated using the Vacuum Assisted Resin Transfer Molding (VARTM) process. The beams were fabricated in two parts comprising the bottom shell, complete with tension reinforcing and a top flange fabricated in a separate mold. Prior to attaching the top flange on the last beam fabricated, HTI dropped the bottom FRP shell off of the dollies used to maneuver the beam in the shop. As a result, the webs of the

beam were compromised and this beam was rejected and not incorporated into the final structure. An additional beam was fabricated. In total, Bridge B0439 comprises 15 beams that were sent in two separate shipments of 8 beams and 7 beams on each truck.

Complete records of the fabrication of each beam for B439 are contained in Appendix F, prepared by HRV Conformance Verification Associates, Inc., who served as the quality assurance representatives in HTI's facilities during fabrication.

4.2 ADHESIVE BONDS

The two halves of the HCB FRP shell are fabricated independently and then joined together prior to shipment. Before attaching the top flanges, two ½ inch diameter strands are installed in the bottom of the arch and run the full length of the beam. Tie wires are attached to the strands so that they can be lifted up during installation of the shear connectors. The bottom legs of the shear connectors are then developed below the strand. The strand also serves to provide some tensile and bending capacity to the arch in the event of localized bending or complete decompression of the arch at any point along the arch.

The top flanges and bottom FRP shells are glued together using a combination of methyl methacrylate adhesives (MMA) and ¼ inch, self-tapping stainless steel screws. The MMA adhesives actually fuse the two adjacent laminates together resulting in a very strong bond between the two portions of the beam. This bond is very important to make sure that the top flange acts compositely with the bottom part of the shell during erection and casting of the arch concrete. Although this shear transfer is important during installation of the bridge, once the concrete deck is acting compositely with the HCB, the shear transfer between the FRP flange and the bottom shell is not critical. That being said, the shear stresses in the MMA interface are well below the capacity of these adhesives. The stainless steel screws are not factored into the shear transfer, but do provide a clamping force to spread out the MMA adhesives during gluing. The screws also provide a belt and suspenders effect to arrest any crack that might propagate through the adhesive bond.

4.3 BEARING DETAILS

HCB bridges can be constructed using any number of different bearing configurations. Bridge B0439 has been constructed using integral abutments where the ends of the beams have been cast directly into the pile caps. The HCBs have been erected in a plum orientation along the profile grade of the roadway. Each end of the HCB is supported on a laminated neoprene bearing pad with plan dimensions of 8" by 1'-10". The neoprene pads have been tapered to account for the longitudinal grade. The bearing pads are centered on the centerlines of the beams directly below the "chimney", which is a vertical shaft of concrete at the ends of the beams that is cast integrally with the arch concrete.

The same neoprene pads are also used at the intermediate supports at each pier. Since the neoprene pads do not extend all the way to the edges of the abutment pile caps or pier caps, there is a piece of ½" thickness preformed joint filler (PJF) placed in line with the neoprene pads and extending to the edges of the caps. The intent of this PJF is to make sure that there is no hard spot that will pick up the load of the HCB when there are rotations from bending. Just as it is not desirable to allow any concrete under the front edge of the HCB, it is also desirable to prevent other objects, materials or creatures from migrating into this space. Hence the PJF seals the front edges of the beams with a soft compressible material that will not pick up any load.

As part of the biennial inspections, the front faces of the abutments and pier caps should be inspected to make sure that the PJF is still in place and there is nothing else intruding on this space. It is not anticipated that either the neoprene pad or the PJF will be displaced. If for any reason, either of these materials is extruded from the space beneath the beam, it is suggested that the space be injected with some type of sealant such as a high-grade silicone or polyurethane.

4.4 PARAPET DETAILS

There is nothing unique about the parapet details on Bridge B0439. The concrete barriers, including all reinforcing bars conform to MODOT standard details for safety barrier curb. Inspection and maintenance of these components requires no special consideration because of the HCB framing system.

4.5 DRAINAGE DETAILS

Due to the 180'-10" overall length of B0439, a couple of slab floor drains are required on each side of Span 3-4. The deck drains themselves are a MODOT standard. The attachments deviate from the MODOT standard as inserts and

bolted attachments are less than desirable on the sides of the HCB. The same 10 gage metal strips are used to wrap around the downspout, but the straps are screwed into two pultruded FRP spacer beams that are attached to the sides of the fascia beams. The same MMA adhesives used to attach the top flanges have been used to attach FRP spacer beams to the sides of the fascia beams.

The stresses on these attachments are very low and the spacer beams are not anticipated to need any maintenance. In the off chance that the spacer beams become disconnected from the FRP shell, they should be reattached to the sides of the fascia beams. Similarly, if it becomes necessary in the future to attach other appurtenances to the HCB's, the same MMA adhesives are recommended. When utilized the substrates should be thoroughly cleaned and properly prepared in accordance with any manufacturer's recommendations. It is also possible to utilize self-tapping, stainless steel screws to attach appurtenances to the HCB shells. Depending on the size and spacing of screws, they will likely not impact the structural performance for the HCB shell. Regardless, HC Bridge Company, LLC should be consulted prior to introducing any penetrations in the FRP laminates on an HCB.

4.6 SEQUENCE OF INSTALLATION

Bridge B0439 was constructed during the summer and fall of 2011 by KTU, which comprised a joint venture of Kiewit, Traylor Brothers and United. As there are a number of different ways to install an HCB bridge, the following section will detail the specific installation sequence of this bridge to provide further insight for future maintenance and inspection.

Assembly of Beams

As noted previously, all of the beams were fabricated by HTI in Brunswick, ME and shipped to a staging yard near Jackson Mill, MO. The beams were delivered in two shipments of 8 beams and 7 beams each in July of 2011. Prior to shipment, holes were drilled in the top flanges and the shear connectors were preinstalled by HTI. Additional holes were also drilled in the sides of the beams at the chimney locations to accommodate reinforcing steel for the integral pile caps (diaphragms) cast at the abutments and over the piers. Holes were also predrilled at the ends of the beams at the bottom of the chimneys to accommodate reinforcing steel that extends from the ends of the beams to provide continuity with the cast-in-place diaphragms. The exterior surfaces of the fascia beams were also coated with a UV inhibiting gel coat (paint) prior to shipment.

4.6.1 Casting of Arch-Compression Reinforcement

The next stage of assembling the HCB Bridge involved casting of the concrete into the arch ribs. This part of the construction sequence can either be done prior to erecting the HCB or after the beams have been placed on the supports. For this particular bridge, the Contractor elected to pre-fill the compression reinforcement in the arches prior to erecting the HCBs. All of the beams were set up in a staging yard adjacent to a local Ready-Mix concrete batch plant.

Whatever camber was required to accommodate arch casting and deck casting was built into the beams during the fabrication process. Regardless, to ensure the proper amount of camber was left in the beams to accommodate the deck casting, each of the fifteen beams was supported by timber blocking at the ends as well as intermediate shoring to make sure that the desired deflections would not be exceeded during casting of the arch concrete.

In order to feel comfortable with the placement of the arch concrete, KTU elected to build a mock-up prior to filling the actual beams. The mock-up consisted of one half of a beam constructed as a mold with plywood forms and one side of clear Plexiglas so that the concrete would be visible during placement. This experiment proved to be successful and demonstrated that the entire void would be filled during placement. In August 2011, the fifteen HCBs for the permanent structure were successfully filled using a 6,000 psi Self-Consolidating Concrete (SCC) mix. Five holes were provided for filling of the concrete, including one at the centerline of the beams, one at each chimney and one about a quarter of the length along the beam at each side.

Figure 4.1 shows the beams in the precasting yard as they are being loaded for delivery to the bridge site. It should be noted that once the beams are filled with concrete, they must be lifted from the ends. Strand lifting loops were placed in the chimneys prior to casting of the arch concrete. These loops were removed once the HCB units were set on the substructure. Other items cast into the beams during arch concrete placement included inserts to anchor the overhang brackets on the fascia beams as well as posts to support the Bidwell screed along the fascia beams. Also included were the bars extending transversely out of the diaphragms for the cast-in-place closures between the beams as well as the bars extending out of the ends of the beams.



FIGURE 4.1 HCBs in staging yard prior to shipping to bridge site

4.6.2 Shipping and Erection

Once the concrete arches are cast in the HCB unit, some of the weight advantage is lost. Whereas the empty shells for B0439 weigh on the order of 3,400 lbs, once the concrete arches are filled, the individual beams weigh closer to 13,500 lbs. Although this is over four times the weight of the empty shell, the HCB units are still 1/3rd the weight of a conventional precast concrete box beam. Regardless, with the additional weight, it was easier to ship the beams to the job site with two beams to a truck. The three equal spans of 60 feet each were then set using a crawler crane as depicted in Figure 4.4 in October 2011.



FIGURE 4.52 Setting pre-filled HCB's in on substructure

4.6.3 Casting of Composite Concrete Deck and Parapets

There are many different ways to place a concrete deck on top of an HCB framed bridge as well. B0439 was designed to be constructed using 3” deep precast, prestressed concrete planks spanning between the beams with a 5-1/2” cast-in-place (CIP) deck cast on top of the planks. The CIP deck has a single layer of reinforcing steel placed over the tops of the planks with 2-3/4” of cover. The bridge is also designed to be continuous for live loads over the intermediate piers, making it a 3-span continuous beam. Providing an additional 48- #8 bars in the top slab, running longitudinally over the piers, facilitates the continuity. Consequently, any negative moments over the piers are resisted by tension in the additional #8 bars and compression in the CIP integral pier caps at the intermediate piers. At sections away from the piers, the force couple between the #8 bars and the concrete arch concrete in the HCB resist the negative moments.

Although bridge B0439 is designed as a continuous 3-span structure, the HCB units have adequate capacity to resist the factored moment demand even as simply supported units. Subsequently loss of reinforcing steel over the piers will not result in an unsafe condition, although the live load deflections could increase marginally. Regardless, any deck reconstruction in the future, should include provisions for the continuity steel in the deck over the piers.

Another consideration for future inspections involves looking at the concrete in the reinforced concrete pier caps/diaphragms. Similar to a concrete bridge, all of the lateral forces applied to the bridge are resisted through the substructure components, including the CIP diaphragms. The concrete in the chimneys of the HCBs serves as an integral component of the transverse diaphragms. It is not anticipated that the deck and/or diaphragms on an HCB bridge should perform any differently than on a conventional bridge structure. If there is any cracking of the CIP diaphragm concrete, it should be noted.

The deck and parapets for bridge B0439 were cast in November and the bridge was opened to normal service traffic shortly thereafter.

5.0 INSPECTION AND MAINTENANCE

One of the more pertinent questions consistently raised relates to the inspection and maintenance of the HCB. It is not possible to thoroughly address this concern within the confines of this manual, a good reference is NCHRP Report 564, *Field Inspection of In-Service FRP Bridge Decks*. Although the FRP decks and bridge elements addressed in this report are more consistent with homogenous FRP structures, many of the NDE techniques discussed and explanations of characteristics of FRP performance are applicable to the HCB.

5.1 INSPECTION METHODS

In terms of maintenance and inspection of highway bridges, federal laws mandate that biennial inspections be performed for all bridges on the National Bridge Inventory (NBI). Different states may have different forms and processes that are incorporated as part of these inspections, however most follow recommendations contained in *The Manual for Condition Evaluation of Bridges* published by the American Association of State Highway and Transportation Officials (AASHTO). Due to the fact that composite bridge components have only recently found their way into the NBI, limited information has been available in the past for purposes of inspecting these types of bridges.

Although composite structures manufactured from pultruded FRP's have been in service for over thirty years, the first all composite vehicular bridges were not really introduced until around 1994. Since that time, nearly one-hundred bridges utilizing FRP composite decks of various types have been constructed in the United States. It was the long-term monitoring and evaluation of these bridges that prompted the National Cooperative Highway Research Program (NCHRP) to commission a study related to this subject. What resulted was *NCHRP Report 564 – Field Inspection of In-Service FRP Bridge Decks* (Telang, et.al., 2006).

This study was focused on composite bridge decks, however the characteristics of, and constituent properties of some of the decks investigated are very similar to those of the HCB. Subsequently, most of the information in the report is equally applicable to the HCB. In addition to inspection and maintenance issues, NCHRP Report 564 serves as an excellent reference providing an overview of composite manufacturing for bridge related products and somewhat of an anthology of composite bridge construction to date.

The NCHRP report also contains useful information regarding suggested forms for summarizing inspection data when evaluating composite bridge decks as well as a bridge condition rating table that categorizes the severity of the condition of the bridge components on a scale from 0 to 9, consistent with condition ratings for conventional bridge components as outlined in the *Recording and Coding Guide for the Structures Inventory and Appraisal of the Nation's Bridges* as published by FHWA.

In order to effectively utilize the information in NCHRP Report 564 it is worth noting particular types of damages and defects for which the HCB may be prone. To this extent, Report 564 is primarily useful only in evaluating the FRP components of the HCB. The other components including the internal arch concrete and the embedded steel reinforcing are not addressed in the Report 564.

FRP Laminates: The potential FRP damage types suggested in NCHRP Report 564 include the following list. Comments specific to the HCB have been interjected to provide some guidance to the inspector.

- *Blistering:* To date this has never been seen on an HCB laminate, but might be more evident on an HCB having a gel coat or intumescent paint application.
- *Voids:* To date voids have not been evident in HCB units. In general, the laminates on the HCB are very thin, providing less opportunity for voids during manufacturing.
- *Discoloration:* With the pigments used in the resin, it is difficult to detect discoloration of the resins in the new HCB. This type of damage will likely be more evident with time, such as chalkiness, yellowing or lightening of the color due to UV exposure. This discoloration itself should not be an indication of a problem requiring

mitigation, but may warrant remediation if cracking of the laminate becomes evident. Cosmetic repairs can be made using marine faring compounds or gel coats to fill the cracks.

- *Cracks:* As with concrete, cracking in an FRP laminate can be qualified in different levels of severity. If the cracks are small and do not seem to propagate or increase in severity, no remediation may be necessary. For cosmetic repairs, marine faring compounds or gel coats may be applied. If the cracks appear to be more analogous to tearing or delamination, see the recommendations below.
- *Delamination:* Delaminations have been evident in laboratory testing of HCBs, but only at loads in excess of factored demand. The types of delamination observed generally relates to the debonding of the web laminate from the interior polyiso core. These types of delamination appear to be as a result of high shear loadings causing tension field action in the webs and have usually been obvious from visual observations. As the webs exhibit elastic buckling in shear, portions of the web can delaminate from the foam. This does not necessarily indicate a compromise in the beam capacity. Regardless, if it is clear that the foam has delaminated from the laminate, restoring the bond between the components is desirable.

Although this process has never been necessary, one recommendation would be to perform a vacuum infusion of adhesives or vinyl ester resins by drilling a select number of holes in the laminate in strategic locations. A vacuum line should be connected at the highest point and resin feed lines attached to the other hole(s). A low viscosity MMA might provide the best solution. *(Under no circumstances should the voids be pressure injected as the pressure from the pump could cause further delamination of the laminate from the foam).*

If the delamination appears to be of greater severity, e.g. if there is a clear separation of laminate layers or sufficient separation to facilitate moisture ingress into the laminate a more substantial repair may be warranted. These types of repairs may require the services of a specialty consultant/contractor. The repairs might include bonding of carbon or glass fibers to reinforce the section to its initial capacity.

- *Presence of Moisture:* FRP laminates are subject to moisture absorption. For the most part, the FRP laminates in the HCB operate at very low strain levels (typically on the order of 10% of ultimate strain). These low strain levels result in less probability of micro cracking in the matrix and reduced absorption rates. If there is evidence of increased propagation of cracking, it may be necessary to evaluate the need for applying a gel coat to the exterior of the HCB as a moisture barrier.
- *Abrasion or tearing:* This type of damage is not anticipated under normal service operations. However this type of damage might occur due to isolated incidents that could result from stream flows at high water levels or from impact from vehicles below the bridge. If there is any concern about loss of section or capacity, repair methods such as those found in ACI 440 should be investigated to strengthen the HCB.
- *Creep, flow, or rupture:* As the stiffness of the concrete and steel components is very high compared to the FRP laminates, the sustained loads and subsequent stresses on the FRP laminates are very low. Subsequently, creep flow or creep rupture are of little or no concern. One exception to this is where the tension reinforcing might be limited to glass reinforcing. In this case if the sustained dead load on the tension reinforcing exceeds 25% of the ultimate strain of the laminate, then creep rupture may be a more valid concern. In cases where glass has been used as the primary tension reinforcing this criteria has been evaluated carefully in the design.

NCHRP also includes a short list of Non-Destructive Evaluation (NDE) techniques for evaluation of the laminate and the HCB in general. These test methods include the following:

- *Visual inspection and testing*
- *Tap testing*
- *Thermal testing*
- *Acoustic testing*
- *Ultrasonic testing*
- *Radiography*
- *Modal-parameter analysis*

As noted in the NCHRP report, all but the visual inspection and the tap test can be fairly costly or complicated methods. For many of the laminate damage types noted above, these two techniques may be more than adequate most of the time. However, the FRP laminate is only one component of the HCB. The other critical components include the arch concrete and the steel tension reinforcing. Like a concrete beam, the steel reinforcing in the HCB is not visible to the naked eye. As a result, there is always some concern about the condition evaluation of this component. Likewise, the concrete arch is not visible either. Neither the tap test nor visual inspection provides much guidance in condition evaluation of these two components. For the most part, the simple visual and tap test techniques should be sufficient for routine biennial inspections. It is recommended that at the end of ten years of service life, one of the more sophisticated NDE techniques be employed to determine if there is any deterioration or damage to the internal components of the HCB.

Another NDE technique that is becoming more common in the construction industry is “Ground Penetrating Radar” (GPR). This type of technology is used for a multitude of purposes, including location and condition evaluation of reinforcing steel and post-tensioning tendons as well as location of voids in post-tensioning grout. It is also becoming more popular as a technique for finding voids in concrete and condition evaluation of concrete. Although still more expensive than visual inspection and tap testing, this technology is becoming more readily available and may be warranted for a more thorough investigation than would be conducted under a normal biennial inspection.

It should be noted that the tension steel is protected by several barriers including; no less than ¼” of high quality FRP laminate, complete encasement in the same vinyl ester resin as the laminate and a galvanized coating. Further, as noted before, the quantity of steel is typically on the order of twice that required for ultimate bending capacity. Likewise, the concrete arch is almost always in compression and is completely encapsulated. With proper placement of the concrete during construction, it is not likely that there will be any degradation of this component under normal service operations.

5.2 DETERMINATION OF RATING FOR HCB

As stated before, due to the newness of the HCB structures and the anticipated durability of the materials, there is no statistical database of damage or deterioration for assessing the condition rating of this portion of the bridge superstructure. Regardless, it is important to provide the inspector with some type of guidance in assessing the condition of the HCB to determine a consistent rating as is done with other types of bridge subcomponents. The following is to serve as a guideline to the inspector with respect to determination of the condition rating consistent with a scale ranging from 0 to 9. It should be noted that the current condition rating is purely based on the current understanding of the performance of the HCB and the FRP materials comprising the beams. It is also based on speculation of what types of damage and or degradation might result over time and how these might relate to similar ratings for other types of materials used in bridge superstructures. The inspector should exercise the proper standard of care in the assessment of the condition ratings and be cognizant of the likelihood that over time these condition assessments may need to be calibrated based on observed performance of the HCB.

Rating 9: Excellent Condition.

- A. No deficiencies noted.

Rating 8: Very Good Condition. *Potential exists for minor preventive maintenance.*

- A. No noticeable or noteworthy deficiencies that affect the condition of the superstructure.
- B. Insignificant cosmetic blemishes.

Rating 7: Good Condition. *Potential exists for minor maintenance.*

- A. Minor cracking in laminate matrix evident in the surface either from UV exposure, weather related damage or impact.
- B. Abrasion or scratches on the surface of the laminate, but do not penetrate the fibers.
- C. Small holes in the laminate due to impact or vandalism (e.g. bullet holes).
- D. Blistering or noticeable bubbles on the surface or gelcoat where applied.
- E. Minor concrete cracking in the cast-in-place diaphragms at piers and/or abutments.

Rating 6: Satisfactory Condition: *Potential exists for major maintenance.*

- A. Cracking and/or damage to the laminate with no evidence of damage or deterioration of the steel strands in the tension reinforcement.
- B. Abnormal undulations or mounds seen on the otherwise flat surface of the FRP surfaces on the HCB.

- C. The presence of moisture stains on the underside, away from the deck interface with no visible path for water collection. This could be a sign of porosity in the laminate.
- D. Heavy leaching through concrete diaphragms at girder encasement of integral bents.

Rating 5: Fair Condition: *Potential exists for minor rehabilitation.* No affect on structural capacity.

- A. Significant delamination of FRP from foam core.
- B. Exposure of steel tension reinforcement or concrete compression reinforcement through the laminate.
- C. Abrasion or scratches in the FRP laminate resulting in exposure of or severing of glass fibers.
- D. Collision or impact damage to FRP laminates.
- E. Considerable open cracking of concrete diaphragms at girder encasement of integral bents.
- F. Evidence of tearing of the FRP laminate along surfaces or at corners.

Rating 4: Poor Condition: *Potential exists for major rehabilitation.* Some affect on load capacity. Blocking or shoring may be required as precautionary measure.

- A. Evidence of rust or significant exposure of the steel tension reinforcement.
- B. Evidence of significant deterioration or crushing of the concrete compression reinforcement.
- C. Collision or impact damage resulting in large tears or penetrations of the FRP laminate, severing of tension or compression reinforcement, or any visibly evident significant distortions in the geometry of the HCB shell.
- D. Rust or spalling of concrete at the anchorage zones of the beam or in the concrete diaphragms at girder encasement of integral bents.
- E. Section loss of the laminate due to exposure to fire.

Rating 3: Serious Condition: *Repair or rehabilitation required immediately.*

- A. Any condition described in Rating 4, which is of a severe magnitude or for which blocking, shoring or load restrictions are necessary.
- B. Excessive deflections evident in the beams.

Rating 2: Critical Condition: **CRITICAL INSPECTION FINDING.** The need for repair or rehabilitation is urgent. Facility should be closed until the indicated repair is completed.

- A. Structure on verge of collapse or portion of superstructure has failed.

Rating 1: “Imminent” Failure Condition – facility is closed. **CRITICAL INSPECTION FINDING.** *Study should determine feasibility for repair. Corrective action may put structure back into light service.*

Rating 0: Failed Condition – facility is closed and beyond repair. *Replacement of structure is necessary.*

Again, the rating determinations shown above most likely will evolve over time as historical data related to the service performance of HCB bridges is documented. These suggested rating determinations are intended to be for the HCB component of the superstructure only. Other components of the bridge should be evaluated based on the criteria established in the *Critical Inspection Findings Missouri Bridge and Culvert Rating Guidelines*.

5.3 STRUCTURAL HEALTH MONITORING

One of the NDE methods listed in Report 564 also warrants further discussion not only for periodic inspections, but also for real time evaluation of the bridge. Currently there are a number of companies and universities focused on modal analysis of structures for damage assessment. Of the more sophisticated methods currently available, this technology seems to be benefitting from the evolution of consumer electronics. Many of these systems use simple accelerometers and wireless transmission technology to reduce the cost of instrumentation and data acquisition. Further, without having to know exactly where damage has occurred on a structure, these methods have the ability to triangulate off of an array of sensors and actually isolate location of damage that may not be evident from other means of investigation.

In general, these modal analysis techniques map a damage probability index based on acquiring a frequency response at some of the higher modes of vibration in an excited structure. In most cases the excitation can just be ambient traffic. It should be noted that a more accurate assessment of a structure results if there is a baseline measurement of the frequency response of the structure, e.g. if measurements are taken in a new bridge before any damage or degradation has occurred.

This technology is rapidly evolving and although no clear front-runner has evolved, this does appear to be a technology well suited to the HCB and other structures where critical structural components may not be visible.

5.4 REPAIRS

There are already well established methods for conventional repairs to prestressed concrete beams as well as steel beams, including localized patching of concrete and heat straightening of steel beams. Other methods that have recently evolved include bonding of carbon fibers to both concrete and steel girders for purposes both of repairing the girders as well as upgrading the capacities of these girders. It should be noted that the composite strengthening systems that have been developed have become rather common place and further lend themselves better to the repair of a composite laminate than they do concrete or steel. These FRP strengthening systems would be recommended for damage to the actual HCB shell.

Currently AASHTO is working towards Design Guide Specification for strengthening of concrete bridges using FRP laminates bonded to the existing structure. These technologies will, for the most part, parallel extensive work that has been done in ACI Committee 440 for the last two decades. The owner is encouraged to use these references for guidance in evaluating structural repairs to damaged HCB bridges.

It should be noted that the FRP strengthening criteria and methods developed for concrete sometimes require remediation to the concrete substrate prior to application. The same would be true for the HCB, although due to the completely different embodiment of the beam, the remediation measures will be different. In general, it is recommended that any unsuitable laminate be cut out of the structure. If there is damage to the foam core, the foam should be repaired and restored to the original geometry prior to bonding any new materials. If the foam is accessible, any damaged foam can be routed out. The surface can then be restored with simple spray in closed-cell expansive foams like “Great Stuff” that can be found at the local hardware store. If the repairs are extensive a specialty contractor and/or consultant should be contacted.

5.5 DECK REPLACEMENT

It is entirely likely that at some point during the life of the HCB Bridge, it will be necessary to replace the deck. In most applications the deck system on an HCB is no different from the reinforced concrete decks used on concrete or steel bridges. In fact the first HCB bridge ever constructed was a 30-foot railroad bridge constructed as part of the HSR-IDEA project. The only damage evident from the initial testing was cracking in the 4-inch concrete deck due to insufficient reinforcing. The deck on this bridge was subsequently removed and reconstructed a year later before resuming testing.

There are several precautions that should be taken in replacing the deck on an HCB Bridge. In most cases the HCB framing will have adequate capacity to support the removal equipment, however care should be taken in removal of the existing deck to make sure that the top flanges and more importantly the concrete fins above the arches are not damaged. It would be well advised to limit the size of the equipment allowed for removal of the deck concrete. It would also be preferable to use “chisel” type bits, instead of “pointed” bits to avoid penetrating the laminates. Although the laminates are very durable and can absorb tremendous amounts of energy, it is not impossible to penetrate.

If some damage is sustained to the laminate in the top flange, it should not compromise the structural capacity of the HCB. However prior to casting a new deck, the laminate should be repaired, as a minimum to make sure there are no openings that allow for ingress of water or other materials. Likewise, care should be taken not to damage the shear connectors extending out of the beam. Any damage to the galvanized coating on the shear connectors should be repaired prior to casting a new deck. It may be possible to drill in additional shear connectors, if damaged, but this is less than desirable.

Another consideration for deck replacement is that it may be more difficult to install protective shielding for removal of the existing deck. As the HCB typically does not have flanges extending out at the bottom, there is no simple location to attach the cribbing to support the shields. In some cases, the top flanges of the HCB are adjacent and no shielding is necessary. If it is a requirement, it may be necessary to attach some type of angle or appurtenance to support the shielding.

REFERENCES

1. Hillman, J.R., *Investigation of a Hybrid-Composite Beam System*. High-Speed Rail IDEA Report HSR-23, Transportation Research Board, 2002.
2. www.nationalbridgeinventory.com , NBI Report 2003
3. www.fhwa.dot.gov/bridge/transfer.htm, HBRRP Fund Transfer by State and Fiscal Year
4. Telang, N.M., Dumlao, C., Mehrabi, A.B., Ciolko, A.T., Gutierrez, J., *Field Inspection of In-Service FRP Bridge Decks*, NCHRP Report 564, Washington, DC, 2006
5. Signor, A.W., Chin, J.W., *Effects of Ultraviolet Radiation Exposure on Vinyl Ester Matrix Resins: Chemical and Mechanical Characterization*, Building Materials Division, National Institute of Standards and Technology, Gaithersburg, MD, 2001
6. *ACI 318-05, Building Code Requirements for Structural Concrete and Commentary*, American Concrete Institute, Farmington Hills, MI, 2005.
7. *AASHTO Standard Specifications for Highway Bridges, 17th Edition*, American Association of State Highway and Transportation Officials, 2002.
8. *AASHTO LRFD Bridge Design Specifications*, American Association of State Highway and Transportation Officials.
9. *AASHTO Manual for Condition Evaluation of Bridges*, American Association of State Highway and Transportation Officials.
10. *AREMA Manual for Railway Engineering*
11. Shanafelt G.O., Horn W.B., *Damage Evaluation and Repair Methods for Prestressed Concrete Bridge Members*, NCHRP Report 226, Washington, DC, 1980.
12. Abendroth, R., Fanous, F., *Lateral Impacts to PC Girders in Bridges with Intermediate Diaphragms*, Proceedings of the 2003 Mid-Continent Transportation Research Symposium, Ames, Iowa, 2003.
13. CHBDC Canadian Highway Bridge Design Code CAN/CSA-06-06, 2006
14. Collins, M.P., Bentz, E.C., Serwood, E.G. and Xie, L. 2008. An Adequate Theory for the Shear Strength of Reinforced Concrete Structures. *Magazine of Concrete Research*, 60, No.9: 635-650.
15. CHBDC Canadian Highway Bridge Design Code CAN/CSA-06-06, 2006

APPENDIX A – Design Calculations

APPENDIX B – Load Rating Calculations

APPENDIX C – Design Drawings & Specifications

APPENDIX D – Shop Drawings

APPENDIX E – QA/QC Documentation

APPENDIX F – Project Information Sheet - Material Certification Reports

APPENDIX G – Laboratory Test Report (Optional)

APPENDIX H – Field Test Report (Optional)